







POWER RELAY SELECTION CHART

Type	HF49FD	HF41F	HF46F
Appearance			
Dimensions(L x W x H) mm	20.0 x 5.0 x 12.5	28.0 x 5.0 x 15.0	20.5 x 7.0 x 15.3
Features	<ul style="list-style-type: none"> • 5A switching capability • 3kV dielectric strength (between coil and contacts) • Surge voltage up to 4kV (between coil and contacts) • Slim size (width 5mm) • High sensitive: 120mW 	<ul style="list-style-type: none"> • Slim size (width 5mm) • 4kV dielectric strength (between coil and contacts) • Surge voltage up to 6kV (between coil and contacts) • High sensitive: 170mW 	<ul style="list-style-type: none"> • 5A switching capability • 10kV impulse withstand voltage (between coil and contacts) • Meets VDE 0631 reinforce insulation • Highly efficient magnetic circuit for high sensitivity: 200mW • Extremely small footprint utilizing PCB area
Contact Ratings			
Contact Form	1A	1A, 1C	1A
Contact Material	AgSnO ₂ , AgNi	AgSnO ₂ , AgNi	AgSnO ₂ , AgNi
Max. Switching Current (Res. load)			
Max. Switching Voltage	250VAC / 30VDC	400VAC / 125VDC	277VAC / 30VDC
Max. Switching Power	1250VA / 150W	1500VA / 180W	1385VA / 150W
Rated Load (Resistive load)	5A 250VAC 5A 30VDC	6A 250VAC 6A 30VDC	3A 250VAC/30VDC 5A 250VAC/30VDC
Coil Ratings			
Rated Voltage	5VDC to 24VDC	5VDC to 60VDC	3VDC to 24VDC
Nominal Operating Power	0.12W to 0.18W	0.17W (48VDC to 60VDC:0.21W)	0.2W
Specifications			
Insulation Resistance	1000MΩ	1000MΩ	1000MΩ
Dielectric Strength (Between coil and contacts)	3000VAC	4000VAC	4000VAC
Ambient Temperature	-40°C to 85°C	-40°C to 85°C	-40°C to 85°C
Operate / Release Time max.	10ms / 5ms	8ms / 4ms	10ms / 10ms
Mechanical Endurance min.	2 x 10 ⁷ OPS	1 x 10 ⁷ OPS	5 x 10 ⁶ OPS
Electrical Endurance min.	1 x 10 ⁵ OPS (at 3A 250VAC/30VDC)	1A: 6 x 10 ⁴ OPS (at 85°C) 1C: NO: 3 x 10 ⁴ OPS (at 85°C) NC: 1 x 10 ⁴ OPS (at 85°C)	1.2 x 10 ⁵ OPS (at 3A 250VAC/30VDC)
Layout (Bottom view)			
Terminal Type	PCB	PCB	PCB
Approved Standards	UL/CUL TÜV CQC	UL/CUL VDE CQC	UL/CUL VDE CQC
File No.	E133481 R50149334 CQC10002049162	E133481 40020043 CQC17002175724	E134517 40025215 CQC08001024932
Cross Reference	OMRON: G6DS PANASONIC: PA FUJITSU: RB/NY SCHRACK: PCN	PANASONIC: PF FUJITSU: FTR-LY SCHRACK: V23092/SNR FINDER: 34.51	OMRON: G5NB/G5T PANASONIC: LD FUJITSU: FTR-F3
Page	102	105	109

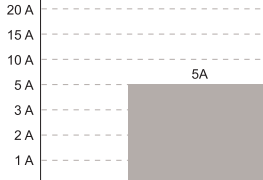
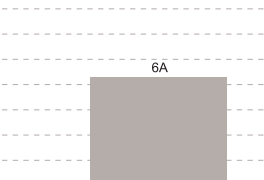
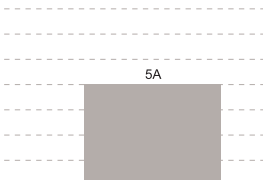
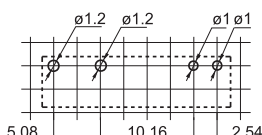
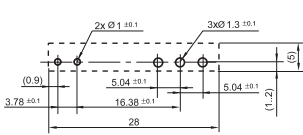
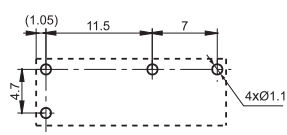

Note: Specification and dimensions in this catalog are subject to change without notice.

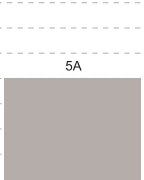
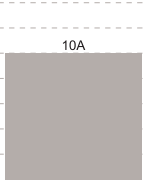
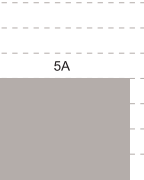
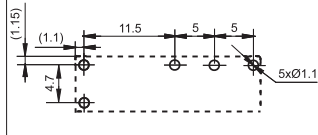
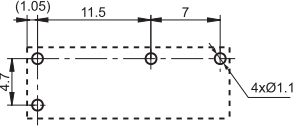
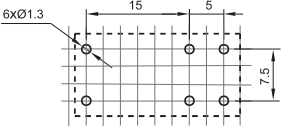
POWER RELAY SELECTION CHART

Type	HF46FB	HF46F-G	HF42F
Appearance			
Dimensions(L x W x H) mm	23.4 x 7.0 x 15.3	20.5 x 7.0 x 15.3	24.4 x 12.8 x 24.8
Features	<ul style="list-style-type: none"> • 5A switching capability • 8kV impulse withstand voltage (between coil and contacts) • Meets reinforce insulation • width 7mm, Suitable for PCB intensive installation • UL insulation system: Class F 	<ul style="list-style-type: none"> • 10A switching capability • 10kV impulse withstand voltage (between coil and contacts) • Meets VDE 0631 reinforce insulation • Highly efficient magnetic circuit for high sensitivity: 200mW • Extremely small footprint utilizing PCB area 	<ul style="list-style-type: none"> • 5A switching capability • TV-3 125VAC approved by UL standard • 2 Form A slim configuration
Contact Ratings			
Contact Form	1C	1A	2A
Contact Material	AgNi	AgSnO ₂ , AgNi	AgSnO ₂ , AgCdO
Max. Switching Current (Res. load)			
Max. Switching Voltage	250VAC	277VAC / 30VDC	250VAC / 30VDC
Max. Switching Power	1250VA	2770VA / 300W	1250VA / 150W
Rated Load (Resistive load)	5A 250VAC	7A 250VAC/30VDC 10A 250VAC/30VDC	5A 250VAC / 30VDC
Coil Ratings			
Rated Voltage	3VDC to 24VDC	3VDC to 24VDC	5VDC to 48VDC
Nominal Operating Power	0.36W	0.2W	0.53W
Specifications			
Insulation Resistance	1000MΩ	1000MΩ	1000MΩ
Dielectric Strength (Between coil and contacts)	4000VAC	4000VAC	4000VAC
Ambient Temperature	-40°C to 85°C	-40°C to 105°C (AgNi contacts) -40°C to 85°C (AgSnO ₂ contacts)	-40°C to 70°C
Operate / Release Time max.	10ms / 10ms	10ms / 10ms	15ms / 10ms
Mechanical Endurance min.	5 x 10 ⁶ OPS	5 x 10 ⁶ OPS	1 x 10 ⁷ OPS
Electrical Endurance min.	5 x 10 ⁴ OPS	6 x 10 ⁴ OPS	5 x 10 ⁴ OPS (at 5A 250VAC)
Layout (Bottom view)			
Terminal Type	PCB	PCB	PCB
Approved Standards	UL/CUL VDE CQC	UL/CUL VDE CQC	UL/CUL TÜV CQC
File No.	E134517 40049080 CQC17002177913	E134517 40025215 CQC08001024932	E133481 R50278397 CQC09002034521
Cross Reference	FUJITSU: FTR-F3	OMRON: G5NB/G5T PANASONIC: LD FUJITSU: FTR-F3	OMRON: G5PA-2 PANASONIC: LA FUJITSU: FTR-F4 NEC: CN OEG: OSA/PCI
Page	112	114	117

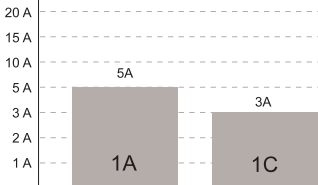
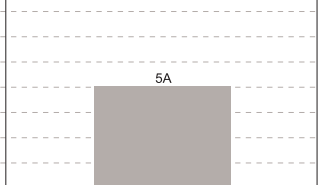
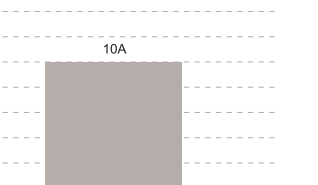
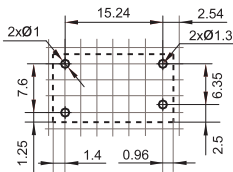
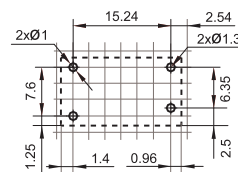
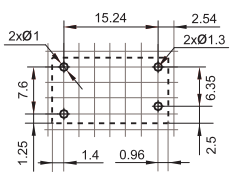

Note: Specification and dimensions in this catalog are subject to change without notice.

POWER RELAY SELECTION CHART

Type	HF32FA	HF32FA-T	HF32FA-G
Appearance			
Dimensions(L x W x H) mm	17.6 x 10.1 x 12.7	17.6 x 10.1 x 12.7	17.6 x 10.1 x 12.7
Features	<ul style="list-style-type: none"> • 5A switching capability • Creepage/clearance distance>8mm • 5kV dielectric strength (between coil and contacts) • 1 Form A meets VDE 0700/0631 • 1 Form C meets VDE 0631 	<ul style="list-style-type: none"> • High temperature: 105°C • 5A switching capability • Creepage/clearance distance>8mm • 5kV dielectric strength (between coil and contacts) • Meets VDE 0700/0631 reinforce insulation 	<ul style="list-style-type: none"> • 10A switching capability • Creepage/clearance distance>8mm • 5kV dielectric strength (between coil and contacts) • Meets VDE 0700/0631 reinforce insulation
Contact Ratings			
Contact Form	1A, 1C	1A	1A
Contact Material	AgNi	AgNi	AgSnO ₂
Max. Switching Current (Res. load)			
Max. Switching Voltage	250VAC / 30VDC	250VAC / 30VDC	250VAC
Max. Switching Power	1250VA / 150W	1250VA / 150W	2500VA
Rated Load (Resistive load)	1A: 5A 250VAC/30VDC 1C: 3A 250VAC/30VDC	5A 250VAC 5A 30VDC	10A 250VAC
Coil Ratings			
Rated Voltage	3VDC to 48VDC	3VDC to 24VDC	3VDC to 48VDC
Nominal Operating Power	0.2W, 0.45W	0.2W	0.23W, 0.45W
Specifications			
Insulation Resistance	1000MΩ	1000MΩ	1000MΩ
Dielectric Strength (Between coil and contacts)	5000VAC	5000VAC	5000VAC
Ambient Temperature	-40°C to 85°C	-40°C to 105°C	-40°C to 85°C
Operate / Release Time max.	8ms / 4ms	8ms / 4ms	8ms / 4ms
Mechanical Endurance min.	1 x 10 ⁶ OPS	1 x 10 ⁶ OPS	1 x 10 ⁶ OPS
Electrical Endurance min.	1 x 10 ⁵ OPS	1 x 10 ⁵ OPS (at 5A 250VAC)	1 x 10 ⁴ OPS
Layout (Bottom view)			
Terminal Type	PCB	PCB	PCB
Approved Standards	UL/CUL VDE CQC	UL/CUL VDE CQC	UL/CUL VDE CQC
File No.	E134517 40006182 CQC17002175721	E134517 40006182 CQC17002175721	E134517 40006182 CQC17002175721
Cross Reference	FUJITSU: JV OEG: OJ/OJE P&B: T77	FUJITSU: JV OEG: OJ/OJE P&B: T77	FUJITSU: JV OEG: OJ/OJE P&B: T77
Page	120	123	126

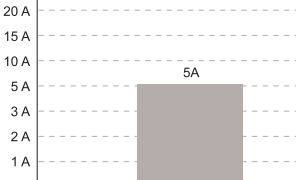
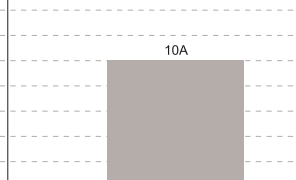
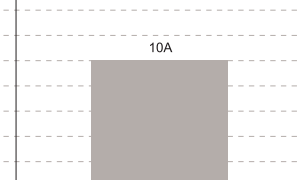
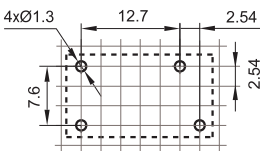
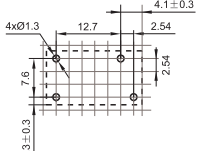
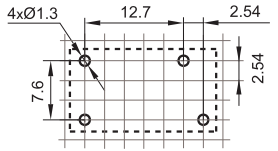

Note: Specification and dimensions in this catalog are subject to change without notice.

POWER RELAY SELECTION CHART

Type	HF32FV	HF32FV-T	HF32FV-G
Appearance			
Dimensions(L x W x H) mm	18.4 x 10.2 x 15.3	18.4 x 10.2 x 15.5	18.4 x 10.2 x 15.3
Features	<ul style="list-style-type: none"> • 5A switching capability • Creepage distance: 6.5mm (between coil & contacts) • Dielectric strength 4kV • Standard PCB layout • Plastic sealed and flux proofed types available • UL insulation system: Class F 	<ul style="list-style-type: none"> • High Temperature:105°C • 10A switching capability • Dielectric strength 4kV (between coil and contacts) • 1 Form A configurations • Standard PCB layout • UL insulation system: Class F 	<ul style="list-style-type: none"> • 10A switching capability • Creepage distance: 6.5mm (between coil & contacts) • Dielectric strength 4kV • Standard PCB layout • Plastic sealed and flux proofed types available • UL insulation system: Class F
Contact Ratings			
Contact Form	1A	1A	1A
Contact Material	AgSnO ₂ , AgCdO, AgNi	AgSnO ₂	AgSnO ₂ , AgCdO, AgNi
Max. Switching Current (Res. load)			
Max. Switching Voltage	277VAC / 30VDC	250VAC	277VAC / 30VDC
Max. Switching Power	1250VA / 150W	2500VA	2500VA / 300W
Rated Load (Resistive load)	5A 250VAC / 30VDC L type: 3A 250VAC / 30VDC	10A 250VAC	10A 250VAC / 30VDC 8A 250VAC / 30VDC (Sensitive Type)
Coil Ratings			
Rated Voltage	3VDC to 48VDC	3VDC to 48VDC	3VDC to 48VDC
Nominal Operating Power	0.2W, 0.45W	0.45W	0.2W, 0.45W
Specifications			
Insulation Resistance	1000MΩ	1000MΩ	1000MΩ
Dielectric Strength (Between coil and contacts)	4000VAC	4000VAC	4000VAC
Ambient Temperature	-40°C to 85°C	-40°C to 105°C	-40°C to 85°C
Operate / Release Time max.	8ms / 5ms	8ms / 5ms	8ms / 5ms
Mechanical Endurance min.	1 x 10 ⁷ OPS	1 x 10 ⁷ OPS	1 x 10 ⁷ OPS
Electrical Endurance min.	1 x 10 ⁵ OPS	1 x 10 ⁵ OPS	1 x 10 ⁵ OPS
Layout (Bottom view)			
Terminal Type	PCB	PCB	PCB
Approved Standards	UL/CUL VDE CQC	UL/CUL VDE CQC	UL/CUL VDE CQC
File No.	E134517 40012204 CQC14002120720	E134517 40012204 CQC14002120720	E134517 40012204 CQC14002120720
Cross Reference	FUJITSU: JV OEG: OJ/OJE P&B: T77	SANYOU:SJ MEISHUO:MPD	FUJITSU: JV OEG: OJ/OJE P&B: T77
Page	129	132	134

Note: Specification and dimensions in this catalog are subject to change without notice.

POWER RELAY SELECTION CHART

Type	HF32FV-16	HF32F	HF32F-G
Appearance			
Dimensions(L x W x H) mm	18.4 x 10.2 x 15.3	18.4 x 10.2 x 15.5	18.4 x 10.2 x 15.5
Features	<ul style="list-style-type: none"> • 16A switching capability • Dielectric strength 4kV(between coil and contacts) • 1 Form A configuration • UL insulation system: Class F • Product in accordance to IEC 62368-1 available 	<ul style="list-style-type: none"> • 1 Form A and 1 Form C configurations • Subminiature, standard PCB layout • Plastic sealed and flux proofed types available • UL insulation system: Class F • Product in accordance to IEC 60335-1 available 	<ul style="list-style-type: none"> • 10A switching capability • 1 Form A configurations • Subminiature standard PCB layout • Plastic sealed and flux proofed types available

Contact Ratings

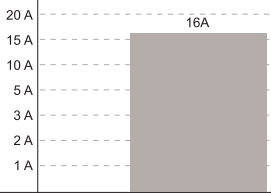
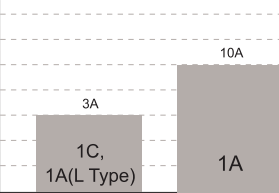
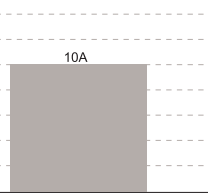
Contact Form	1A	1A, 1C	1A
Contact Material	AgSnO ₂	AgNi, AgCdO	AgSnO ₂ , AgNi, AgCdO
Max. Switching Current (Res. load)			
Max. Switching Voltage	250VAC	250VAC / 30VDC	250VAC / 30VDC
Max. Switching Power	4000VA	1250VA / 150W	2500VA / 300W
Rated Load (Resistive load)	16A 250VAC	1A: 10A 125VAC 5A 250VAC/30VDC L Type: 3A 250VAC/30VDC 1C: 3A 250VAC/30VDC	10A 250VAC 10A 30VDC

Coil Ratings

Rated Voltage	5VDC to 24VDC	3VDC to 48VDC	3VDC to 48VDC
Nominal Operating Power	0.8W, 0.4W(Sensitive Type)	0.2W, 0.45W	0.45W

Specifications

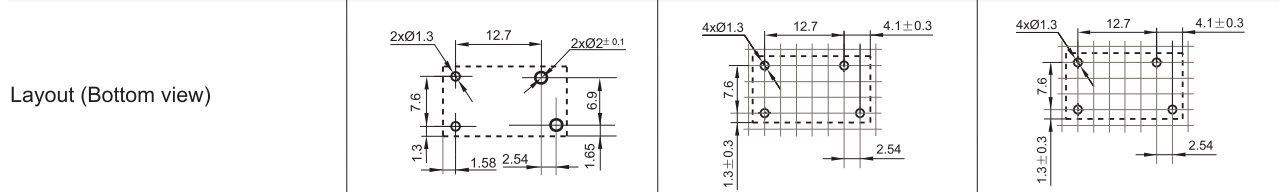

Insulation Resistance	1000MΩ	1000MΩ	1000MΩ
Dielectric Strength (Between coil and contacts)	4000VAC	2500VAC	2500VAC
Ambient Temperature	-40°C to 85°C	-40°C to 70°C	-40°C to 85°C
Operate / Release Time max.	10ms / 5ms	8ms / 5ms	8ms / 5ms
Mechanical Endurance min.	1 x 10 ⁶ OPS	5 x 10 ⁶ OPS	1 x 10 ⁶ OPS
Electrical Endurance min.	1 x 10 ⁴ OPS(at 16A 250VAC) 5 x 10 ⁷ OPS(at 16A 250VAC)	1 x 10 ⁵ OPS	1 x 10 ⁵ OPS



Terminal Type		PCB	PCB
Approved Standards	UL/CUL VDE CQC	UL/CUL VDE CQC	UL/CUL VDE CQC
File No.	E134517 40012204 CQC14002120720	E134517 40012204 CQC12002076528 CQC16002148335	E134517 40012204 CQC12002076528 CQC16002148335
Cross Reference	OEG: OJT GOODSKY:GQ	FUJITSU: JV OEG: OJ/OJE P&B: T77	FUJITSU: JV OEG: OJ/OJE P&B: T77
Page	137	140	143

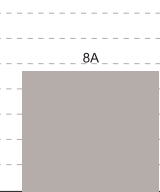
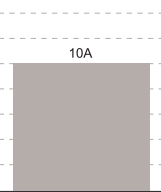
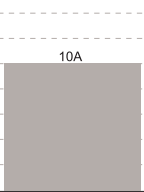
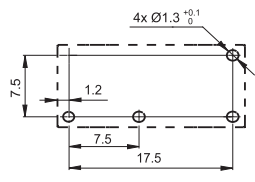
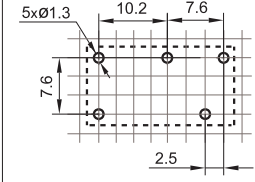
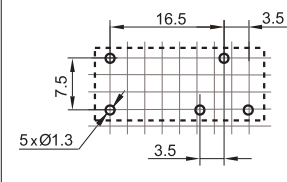

Note: Specification and dimensions in this catalog are subject to change without notice.

POWER RELAY SELECTION CHART

Type	HF171F	HF33F	HF36F
Appearance			
Dimensions(L x W x H) mm	20.0 x 10.0 x 10.6	20.5 x 10.2 x 15.3	23.8 x 9.5 x 24.5
Features	<ul style="list-style-type: none"> • 8A switching capability • 1 form A and 1 form C configurations • High sensitivity 200mW • Creepage/clearance distance:>6mm, meets VDE 0631reinforce insulation • 5KV dielectric between coil to contacts • Class F insulation 	<ul style="list-style-type: none"> • 10A switching capability • Creepage distance:8mm (both for 1 CO and NO) • Clearance distance: NO type 4.5mm; NC type 4mm • Plastic sealed and flux proofed types available 	<ul style="list-style-type: none"> • 10A switching capability • TV-5 125VAC approved by UL standard (only for 1 Form A) • 1 Form A and 1 Form C configurations • Plastic sealed and flux proofed types available
Contact Ratings			
Contact Form	1A, 1C	1A, 1C	1A, 1C
Contact Material	AgSnO ₂ , AgNi	AgSnO ₂ , AgNi, AgCdO	AgSnO ₂ , AgCdO
Max. Switching Current (Res. load)			
Max. Switching Voltage	30VDC / 277VAC	277VAC / 30VDC	250VAC / 30VDC
Max. Switching Power	1662VA / 180W	1250VA / 150W	2500VA / 300W
Rated Load (Resistive load)	1A:6A 250VAC/30VDC 1C:NO:6A 250VAC/30VDC NC:5A 250VAC/30VDC	NO: 10A 125VAC 5A 250VAC/30VDC NC: 3A 250VAC/30VDC	10A 250VAC/30VDC TV-5 125VAC
Coil Ratings			
Rated Voltage	3VDC to 48VDC	3VDC to 48VDC	5VDC to 48VDC
Nominal Operating Power	0.2W	0.2W, 0.45W	0.25W, 0.53W
Specifications			
Insulation Resistance	1000MΩ	1000MΩ	1000MΩ
Dielectric Strength (Between coil and contacts)	5000VAC	4000VAC	4000VAC (NO), 3000VAC (NC)
Ambient Temperature	-40°C to 85°C	-40°C to 70°C	-40°C to 70°C
Operate / Release Time max.	8ms / 5ms	8ms / 5ms	15ms / 5ms
Mechanical Endurance min.	1 x 10 ⁷ OPS	5 x 10 ⁶ OPS	1 x 10 ⁷ OPS
Electrical Endurance min.	1 x 10 ⁵ OPS	1 x 10 ⁵ OPS	5 x 10 ⁴ OPS (at 10A 250VAC)
Layout (Bottom view)			
Terminal Type	PCB	PCB	PCB
Approved Standards	UL/CUL VDE CQC	UL/CUL VDE CQC	UL/CUL TÜV CQC
File No.	E133481 40048577 CQC17002177419	E134517 125661 CQC12002076530 OMRON: G5SB/G5Q PANASONIC: JQ/PQ FUJITSU: JY SCHRACK: RE/REL OEG: PCH	E134517 R50356442 CQC16002159838 OMRON: G5PA-1 PANASONIC: LK FUJITSU: FTR-H2/F2 NEC: CK OEG: SDT
Cross Reference			
Page	145	148	152

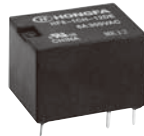
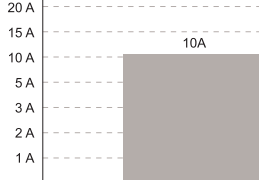
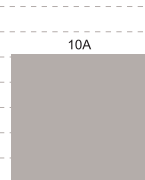
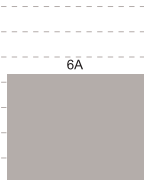
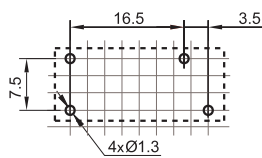
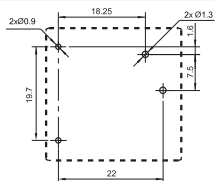
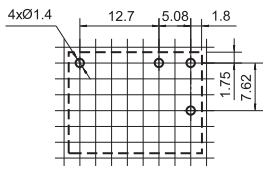

Note: Specification and dimensions in this catalog are subject to change without notice.

POWER RELAY SELECTION CHART

Type	HF36FD	HF162F	HF8
Appearance			
Dimensions(L x W x H) mm	23.8 x 9.5 x 24.5	26.3 x 26.1 x 10.0	21.3 x 16.2 x 14.4
Features	<ul style="list-style-type: none"> • 10A switching capability • TV-8 125VAC approved by UL standard(118A inrush current) • Ideal for device power reduction 	<ul style="list-style-type: none"> • High inrush current: TV-8 125VAC (118A inrush current) • Low height, only 9.3mm (excluding buttons) • High sensitivity: 250mW, • Silent type available 	<ul style="list-style-type: none"> • Sub miniature, high sensitive, Standard PCB layout • 1 Form A and 1 Form C configurations • Plastic sealed type for automatic wave soldering
Contact Ratings			
Contact Form	1A	1A	1A, 1C
Contact Material	AgSnO ₂	AgSnO ₂	AgNi
Max. Switching Current (Res. load)			
Max. Switching Voltage	250VAC / 30VDC	277VAC	300VAC / 30VDC
Max. Switching Power	2500VA / 150W	2216VA	1800VA / 300W
Rated Load (Resistive load)	10A 250VAC 5A 250VAC/30VDC TV-8 125VAC	10A 125VAC 8A/5A 277VAC TV-8 125VAC 3A/100A 250VAC (Capacitive) (Standard type)	HF8: 6A 300VAC/28VDC HF8A: 6A 277VAC/30VDC
Coil Ratings			
Rated Voltage	5VDC to 48VDC	3VDC to 24VDC	3VDC to 48VDC
Nominal Operating Power	0.25W, 0.53W	0.25W	0.33W, 0.45W, 0.6W
Specifications			
Insulation Resistance	1000MΩ	1000MΩ	100MΩ
Dielectric Strength (Between coil and contacts)	4000VAC	4000VAC	2000VAC
Ambient Temperature	-40°C to 70°C	-40°C to 70°C	-55°C to 90°C
Operate / Release Time max.	15ms / 5ms	15ms / 5ms	6ms / 3ms
Mechanical Endurance min.	1 x 10 ⁶ OPS	1 x 10 ⁶ OPS	1 x 10 ⁷ OPS
Electrical Endurance min.	5 x 10 ⁴ OPS (at 10A 250VAC)	5 x 10 ⁴ OPS (at 10A 125VAC)	1 x 10 ⁵ OPS
Layout (Bottom view)			
Terminal Type	PCB	PCB	PCB
Approved Standards	UL/CUL TÜV CQC	UL/CUL VDE CQC	UL/CUL VDE
File No.	E134517 R50356444 CQC16002159846	E133481 40032669 CQC10002050942	E134517 40025189
Cross Reference	OMRON: G5PA-1 PANASONIC: LK NEC: CK OEG: SDT	OMRON: G5PF PANASONIC: LK-F	FUJITSU: LZ P&B: T73 OEG: OUDH
Page	155	157	159

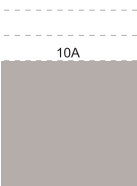
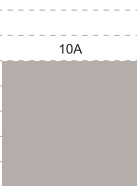
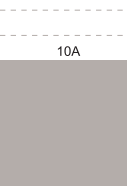
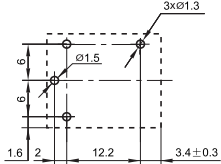
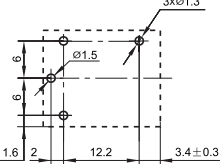
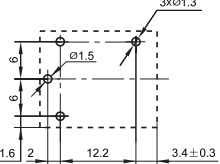

Note: Specification and dimensions in this catalog are subject to change without notice.

POWER RELAY SELECTION CHART

Type	HF3FA	HF3FA-W	HF3FA-T
Appearance			
Dimensions(L x W x H) mm	19.0 x 15.2 x 15.5	19.0 x 15.2 x 16.1	19.0 x 15.2 x 15.5
Features	<ul style="list-style-type: none"> • 15A switching capability • 2.5kV dielectric strength (between coil and contacts) • Flammability class according to UL94, V-0 • CTI 250 	<ul style="list-style-type: none"> • 10A switching capability • Flammability class according to UL94, V-0 • Product in accordance to IEC 60335-1 available • Plastic sealed and flux proofed types available • Subminiature, standard PCB layout • UL insulation system: Class F 	<ul style="list-style-type: none"> • High Temperature:105°C • 15A 125VAC switching capability • Flame resistance rating UL94.V-0 • Product in accordance to IEC 60335-1 available • Subminiature, standard PCB layout • Plastic sealed and flux proofed types available • UL insulation system: Class F
Contact Ratings			
Contact Form	1A, 1C	1C	1A, 1C
Contact Material	AgSnO ₂	AgSnO ₂	AgSnO ₂
Max. Switching Current (Res. load)			
Max. Switching Voltage	277VAC / 30VDC	277VAC / 36VDC	250VDC
Max. Switching Power	2770VA / 280W	2770VA/360W	2500VA
Rated Load (Resistive load)	1A: 10A 250VAC 1C: NO: 10A 250VAC NO/NC: 5A/5A 250VAC	NO: 8A 277VAC/10A 24VDC NC: 5A 250VAC	1A: 10A 250VAC 1C: NO: 10A 250VAC NC: 6A 250VAC
Coil Ratings			
Rated Voltage	3VDC to 48VDC	12VDC and 24VDC	3VDC to 48VDC
Nominal Operating Power	0.36W	0.8W	0.36W
Specifications			
Insulation Resistance	100MΩ	100MΩ(500VDC)	100MΩ(500VDC)
Dielectric Strength (Between coil and contacts)	2500VAC	2500VAC	2500VAC
Ambient Temperature	-40°C to 85°C	-40°C to 85°C	-40°C to 105°C
Operate / Release Time max.	10ms / 5ms	10ms / 5ms	10ms / 5ms
Mechanical Endurance min.	1 x 10 ⁷ OPS	1 x 10 ⁷ OPS	1 x 10 ⁷ OPS
Electrical Endurance min.	1 x 10 ⁵ OPS(NO, at 8A 250VAC)	1 x 10 ⁵ OPS(NO, at 10A 36VDC)	1 x 10 ⁵ OPS(10A 250VAC)
Layout (Bottom view)			
Terminal Type	PCB	PCB	PCB
Approved Standards	UL/CUL VDE CQC	UL/CUL VDE CQC	UL/CUL VDE CQC
File No.	E134517 40023708 CQC12002076529	E134517 40023708 CQC12002076529	E134517 40023708 CQC12002076529
Cross Reference	OMRON: G5LA PANASONIC: JS SCHRACK: T7S SONG CHUAN: 899	GOLDEN:GH-1C	OMRON: G5LA SANYOU:SRDI SONG CHUAN: 833H
Page	162	165	168

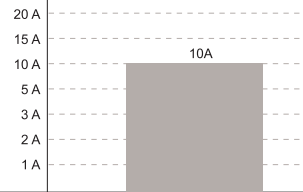
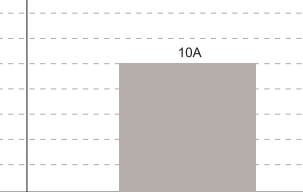
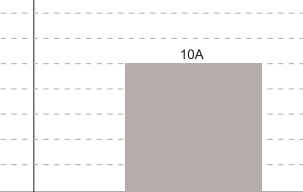
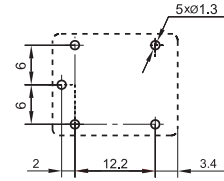
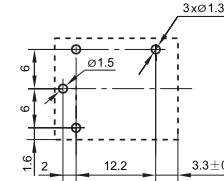
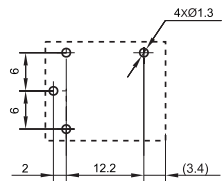

Note: Specification and dimensions in this catalog are subject to change without notice.

POWER RELAY SELECTION CHART

Type	HF3FD	HF3FF	HF3F-L
Appearance			
Dimensions(L x W x H) mm	19.0 x 15.2 x 15.5	19.0 x 15.2 x 15.5	19.0 x 15.2 x 15.5
Features	<ul style="list-style-type: none"> • 15A switching capability • Subminiature, standard PCB layout • Flammability class according to UL94, V-0 • Plastic sealed and flux proofed types available 	<ul style="list-style-type: none"> • 15A 125VAC, 10A 250VAC switching capability • Subminiature, standard PCB layout • 1 Form A and 1 Form C configurations • Plastic sealed and flux proofed types available 	<ul style="list-style-type: none"> • Subminiature high power latching relay • Low coil power • 15A switching capability • 1 Form A and 1 Form C configurations • Subminiature, standard PCB layout • Plastic sealed and flux proofed types available
Contact Ratings			
Contact Form	1A, 1C	1A, 1C	1A, 1C
Contact Material	AgSnO ₂	AgSnO ₂ , AgCdO	AgSnO ₂
Max. Switching Current (Res. load)			
Max. Switching Voltage	277VAC / 30VDC	277VAC / 28VDC	277VAC / 30VDC
Max. Switching Power	2770VA / 300W	2770VA / 280W	2770VA / 300W
Rated Load (Resistive load)	1A: 10A 250VAC 1C: NO: 10A 250VAC NO/NC: 5A/5A 250VAC	10A 277VAC 10A 28VDC	10A 277VAC
Coil Ratings			
Rated Voltage	3VDC to 48VDC	5VDC to 48VDC	5VDC to 48VDC
Nominal Operating Power	0.36W	0.36W (48VDC: 0.51W)	0.4W, 0.8W
Specifications			
Insulation Resistance	100MΩ	100MΩ	100MΩ
Dielectric Strength (Between coil and contacts)	2000VAC	1500VAC	2000VAC
Ambient Temperature	-40°C to 105°C	-40°C to 85°C	-40°C to 85°C
Operate / Release Time max.	10ms / 5ms	10ms / 5ms	8ms / 5ms
Mechanical Endurance min.	1 x 10 ⁷ OPS	1 x 10 ⁷ OPS	1 x 10 ⁷ OPS
Electrical Endurance min.	5 x 10 ⁴ OPS (NO, at 10A 250VAC)	5 x 10 ⁴ OPS (NO, at 10A 250VAC)	1 x 10 ⁴ OPS
Layout (Bottom view)			
Terminal Type	PCB	PCB	PCB
Approved Standards	UL/CUL VDE CQC	UL/CUL VDE TÜV CQC	UL/CUL VDE CQC
File No.	E134517 40014057 CQC14002114760	E134517 40025218 R50148356 CQC13002098175	E134517 40040757 CQC15002121475
Cross Reference	OMRON: G5LB(White) PANASONIC: JS SCHRACK: T7S SONG CHUAN: 899	OMRON: G5LB(Black) PANASONIC: JS P&B: T72 OEG: PCE/ORWH FINDER: 36.11 SONG CHUAN: 833	
Page	171	174	177

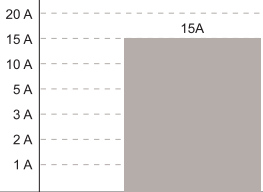
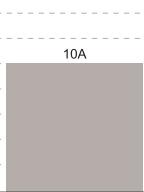
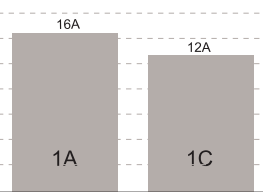
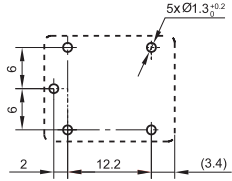
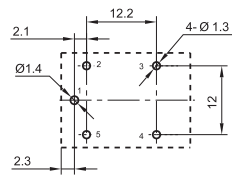
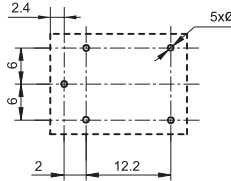

Note: Specification and dimensions in this catalog are subject to change without notice.

POWER RELAY SELECTION CHART

Type	HF3FF-M	HF7FF	HF7FD
Appearance			
Dimensions(L x W x H) mm	19.0 x 15.2 x 15.5	22.5 x 16.5 x 16.5	22.0 x 16.0 x 16.4
Features	<ul style="list-style-type: none"> • 15A switching capability • Subminiature, standard PCB layout • Plastic sealed and Flux proofed types available • RoHS & ELV compliant 	<ul style="list-style-type: none"> • 10A switching capability • Low cost, small package • 1 Form A and 1 Form C configurations • Plastic sealed and flux proofed types available 	<ul style="list-style-type: none"> • 12A switching capability • High performance, Low profile • 2kV dielectric strength (between coil and contacts) • UL94, V-0, CTI250 flammability class
Contact Ratings			
Contact Form	1A, 1C	1A, 1C	1A, 1C
Contact Material	AgSnO ₂	AgSnO ₂ , AgCe	AgSnO ₂ , AgCdO
Max. Switching Current (Res. load)			
Max. Switching Voltage	30VDC	250VAC / 30VDC	250VAC / 28VDC
Max. Switching Power		2400VA / 280W	4000VA / 280W, 2500VA / 196W
Rated Load (Resistive load)	1A: 15A 13.5VDC 1C: NO: 15A 13.5VDC NC: 5A 13.5VDC	10A 250VAC/28VDC 5A 250VAC/30VDC	1A: 16A 250VAC (7FD-T) 12A 250VAC, Double pin, 10A 250VAC 1C: 12A 125VAC (NO) NO/NC: 7A 250VAC
Coil Ratings			
Rated Voltage	9VDC to 24VDC	3VDC to 48VDC	3VDC to 48VDC
Nominal Operating Power	0.45W, 0.64W, 0.80W	0.36W (48VDC: 0.51W)	0.36W
Specifications			
Insulation Resistance	100MΩ	100MΩ	100MΩ
Dielectric Strength (Between coil and contacts)	1500VAC	1500VAC	2000VAC
Ambient Temperature	-40°C to 85°C	-40°C to 70°C	-40°C to 85°C
Operate / Release Time max.	10ms / 10ms	10ms / 5ms	10ms / 5ms
Mechanical Endurance min.	1 x 10 ⁷ OPS	1 x 10 ⁷ OPS	1 x 10 ⁷ OPS
Electrical Endurance min.	1 x 10 ⁵ OPS	1 x 10 ⁵ OPS	5 x 10 ⁴ OPS(1A)
Layout (Bottom view)			
Terminal Type	PCB	PCB	PCB
Approved Standards		UL/CUL CQC	UL/CUL VDE CQC
File No.		E134517 CQC09002028260	E134517 40008374 CQC09002037921
Cross Reference	OMRON: G8SN PANASONIC: JSM SCHRACK: T72N	OMRON: G5LC/G5LE PANASONIC: JSM FUJITSU: CS SCHRACK: T7N OEG: PCE	OMRON: G5LE-VD PANASONIC: JSM FUJITSU: FBR160 NEC: KB SCHRACK: T7N-WG
Page	180	183	186

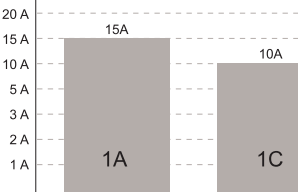
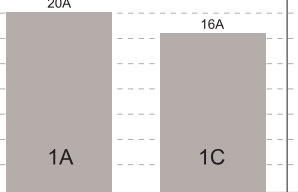
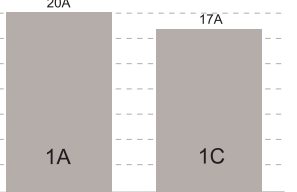
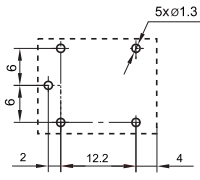
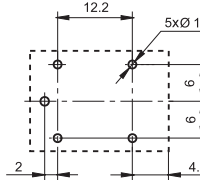
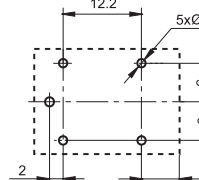

Note: Specification and dimensions in this catalog are subject to change without notice.

POWER RELAY SELECTION CHART

Type	HF21FF	HF152F	HF152FD
Appearance			
Dimensions(L x W x H) mm	20.2 x 16.5 x 20.2	21.0 x 16.0 x 20.6	21.2 x 16.0 x 20.6
Features	<ul style="list-style-type: none"> • 15A switching capability • 1 Form A, 1 Form B and 1 Form C configurations • Standard PCB layout • Plastic sealed and flux proofed available 	<ul style="list-style-type: none"> • 20A switching capacity • Surge voltage up to 6000VAC (between coil and contacts) • 1 Form C and 1 Form A configurations • Plastic sealed and dust protected types available 	<ul style="list-style-type: none"> • 20A switching capability • Ambient temperature meets 105°C • High temperature load: 17A 277VAC at 105°C • 1 Form C & 1 Form A configurations available • Product in accordance to EN 60335-1 available
Contact Ratings			
Contact Form	1A, 1B, 1C	1A, 1C	1A, 1C
Contact Material	AgSnO ₂	AgSnO ₂ , AgNi	AgSnO ₂ , AgNi
Max. Switching Current (Res. load)			
Max. Switching Voltage	120VAC	1A: 400VAC / 1C: 400VAC(NO)	400VAC
Max. Switching Power	1800VA	1A: 4700VA / 1C: 4000VA	4700VA
Rated Load (Resistive load)	1A: 15A 120VAC 1C: 10A 120VAC 1B: 15A 120VAC 1800VA(Ballast)	1A: 20A 125VAC / 17A 277VAC 7A 400VAC 1C: 16A 250VAC NO: 7A 400VAC	1A: 7A 400VAC 17A 277VAC 20A 125VAC 1C: NO:17A 277VAC NC:10A 277VAC
Coil Ratings			
Rated Voltage	5VDC to 48VDC	3VDC to 48VDC	3VDC to 48VDC
Nominal Operating Power	0.36W (48VDC: 0.53W)	0.36W	0.36W
Specifications			
Insulation Resistance	1000MΩ	100MΩ	1000MΩ
Dielectric Strength (Between coil and contacts)	1500VAC	2500VAC	2500VAC
Ambient Temperature	-40°C to 70°C	-40°C to 105°C (HF152F-T)	-40°C to 105°C
Operate / Release Time max.	10ms / 5ms	10ms / 5ms	10ms / 5ms
Mechanical Endurance min.	1 x 10 ⁷ OPS	1 x 10 ⁷ OPS	1 x 10 ⁷ OPS
Electrical Endurance min.	1 x 10 ⁵ OPS	1A: 1 x 10 ⁵ OPS / 1C: 5 x 10 ⁴ OPS	1A: 1 x 10 ⁵ OPS / 1C: 5 x 10 ⁴ OPS
Layout (Bottom view)			
Terminal Type	PCB	PCB	PCB
Approved Standards	UL/CUL	UL/CUL VDE CQC	UL/CUL VDE CQC
File No.	E133481	E134517 40017837 CQC09002034520	E134517 40031203 CQC12002083404
Cross Reference	OMRON: G5L SCHRACK: LN/41896 OEG: SRUDH/SRUUH	OMRON: G5LE-VD PANASONIC: JSM	OMRON: G5LE-VD PANASONIC: JSM SCHRACK: LN-H
Page	189	192	195

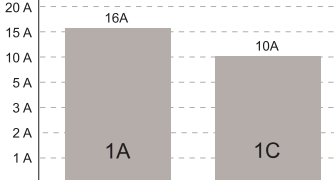
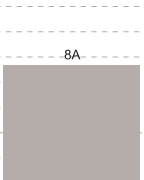
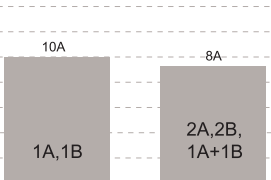
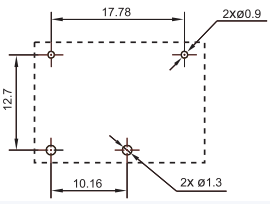
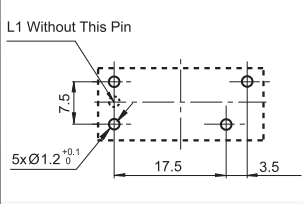
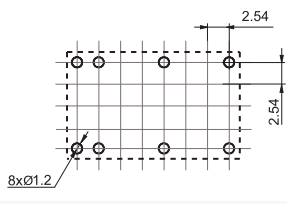

Note: Specification and dimensions in this catalog are subject to change without notice.

POWER RELAY SELECTION CHART

Type	HF7520	HF163F-L	HFE7
Appearance			
Dimensions(L x W x H) mm	22.0 x 16.0 x 10.5	24.0 x 10.0 x 18.8	20.0 x 15.0 x 10.2
Features	<ul style="list-style-type: none"> • Low height, flat construction • 16A switching capability • High sensitive 200mW • PCB & QC terminals available • Plastic sealed and flux proofed types available (with vent-hole cover) 	<ul style="list-style-type: none"> • Latching relay • High sensitive • Breakdown voltage (between contact and coil): 5,000 V • High switching capacity: 8A 250VAC • Surge breakdown voltage(between contact and coil): 12,000 V • Reflow soldering available 	<ul style="list-style-type: none"> • High switching capacity 1A: 10A 250VAC/8A 30VDC; 2A, 1A + 1B: 8A 250VAC/30VDC • High sensitive • 1 Form A, 2 Form A and 1A + 1B contact arrangement • Single side stable and latching types available
Contact Ratings			
Contact Form	1A 1C	1A	1A, 1B 2A, 2B, 1A+1B
Contact Material	AgSnO ₂ , AgNi, AgCdO	AgSnO ₂	AgSnO ₂ , AgNi
Max. Switching Current (Res. load)			
Max. Switching Voltage	250VAC / 30VDC	250VAC / 30VDC	277VAC
Max. Switching Power	4000VA/300W 2500VA/1500VA	2500VA/150W	2500VA 2000VA
Rated Load (Resistive load)	1A: 16A 250VAC 10A 250VAC/30VDC TV-5 1C: NO/NC:10A/6A 125/250VAC	8A 250VAC 5A 30VDC	10A 250VAC 10A 30VDC 8A 250VAC 10A 30VDC
Coil Ratings			
Rated Voltage	5VDC to 48VDC	3VAC to 24VAC / 3VDC to 24VDC	3VDC to 24VDC
Nominal Operating Power	0.2W, 0.4W	0.2W, 0.4W	0.2W, 0.28W, 0.3W, 0.42W
Specifications			
Insulation Resistance	1000MΩ	1000MΩ	1000MΩ
Dielectric Strength (Between coil and contacts)	2500VAC	5000VAC	4000VAC
Ambient Temperature	-40°C to 105°C	-40°C to 85°C	-40°C to 70°C
Operate / Release Time max.	15ms / 5ms	15ms / 15ms	10ms / 10ms
Mechanical Endurance min.	1 x 10 ⁷ OPS	1 x 10 ⁶ OPS	5 x 10 ⁷ OPS
Electrical Endurance min.	5 x 10 ⁴ OPS	5 x 10 ⁴ OPS (at 8A 250VAC)	1 x 10 ⁵ OPS(2 Form A: 3 x 10 ⁴ OPS)
Layout (Bottom view)			
Terminal Type	PCB, QC	PCB	PCB
Approved Standards	UL/CUL TÜV CQC	UL/CUL VDE	UL/CUL VDE
File No.	E133481 R50351269 CQC09002034524	E134517 40039460	E134517 40027342
Cross Reference	OMRON: G5CA PANASONIC: JV/JVN NEC: CQ OEG: PCD	PANASONIC: DW	OMRON: G6C PANASONIC: DK
Page	198	203	206

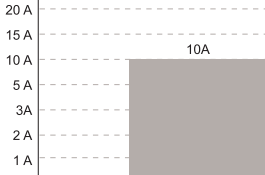
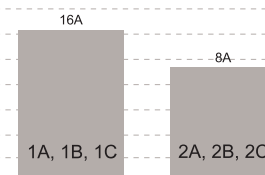
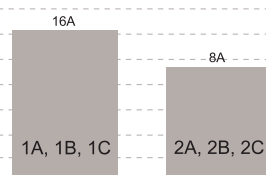
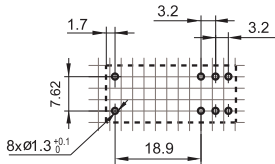
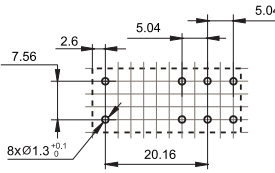
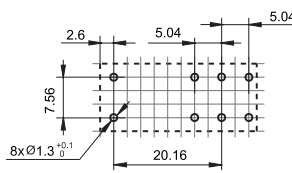

Note: Specification and dimensions in this catalog are subject to change without notice.

POWER RELAY SELECTION CHART

Type	HF118F	HF115F	HF115F-A
Appearance			
Dimensions(L x W x H) mm	28.5 x 10.1 x 12.5	29.0 x 12.7 x 15.7	29.0 x 12.7 x 15.7
Features	<ul style="list-style-type: none"> • 10A switching capability • 5kV dielectric strength (between coil and contacts) • Low height: 12.5 mm • Creepage distance >8mm (VDE0435/0631/0700) • Product in accordance to IEC 60335-1 available 	<ul style="list-style-type: none"> • Low height: 15.7 mm • 16A switching capability • 5kV dielectric strength (between coil and contacts) • Creepage distance: 10mm • Meet VDE0435/0631/0700 • Product in accordance to IEC 60335-1 available 	<ul style="list-style-type: none"> • AC coil voltage type • 16A switching capability • 5kV dielectric strength (between coil and contacts) • Creepage distance: 10mm • Meet VDE0700/0631 • Product in accordance to IEC 60335-1 available
Contact Ratings			
Contact Form	1A, 1B, 1C	1A, 1B, 1C 2A, 2B, 2C	1A, 1B, 1C 2A, 2B, 2C
Contact Material	AgSnO ₂ , AgNi	AgSnO ₂ , AgNi, AgCdO	AgSnO ₂ , AgNi, AgCdO
Max. Switching Current (Res. load)			
Max. Switching Voltage	440VAC / 125VDC	440VAC / 300VDC	440VAC / 300VDC
Max. Switching Power	2500VA/300W	3000VA/4000VA 2000VA	3000VA/4000VA 2000VA
Rated Load (Resistive load)	10A 250VAC 10A 30VDC	16A 250VAC 12A 250VAC 8A 250VAC	16A 250VAC 12A 250VAC 8A 250VAC
Coil Ratings			
Rated Voltage	5VDC to 60VDC	5VDC to 110VDC	24VAC, 115VAC, 230VAC
Nominal Operating Power	0.22W to 0.29W	0.4W	0.75VA
Specifications			
Insulation Resistance	1000MΩ	1000MΩ	1000MΩ
Dielectric Strength (Between coil and contacts)	5000VAC	5000VAC	5000VAC
Ambient Temperature	-40°C to 85°C	-40°C to 85°C	-40°C to 70°C
Operate / Release Time max.	10ms / 5ms	15ms / 8ms	
Mechanical Endurance min.	1 x 10 ⁷ OPS	1 x 10 ⁷ OPS	1 x 10 ⁶ OPS
Electrical Endurance min.	1 x 10 ⁵ OPS (at 8A 250VAC)	1 x 10 ⁵ OPS	5 x 10 ⁴ OPS
Layout (Bottom view)			
Terminal Type	PCB	PCB	PCB
Approved Standards	UL/CUL VDE CQC	UL/CUL VDE CQC	UL/CUL VDE
File No.	E134517 40010480 CQC09002035071	E134517 116934 CQC08002028130	E134517 116934
Cross Reference	OMRON: G6RN FUJITSU: JS SCHRACK: RYII	OMRON: G2RL PANASONIC: LZ SCHRACK: RT FUJITSU: FTR-K1 FINDER: 41 SERIES RELPOL: RM84/85	OMRON: G5RL-AC SCHRACK: RT RELPOL: RM84/85
Page	210	213	217

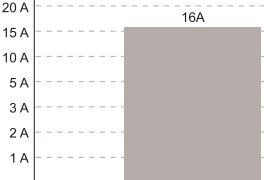
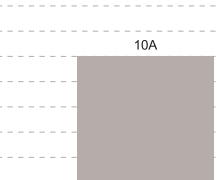
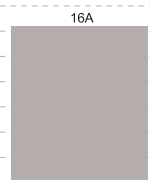
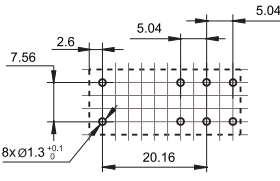
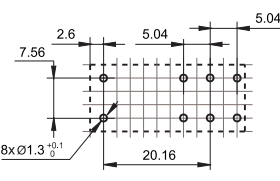
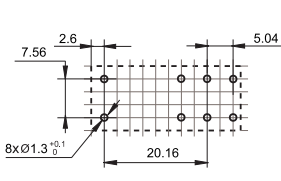

Note: Specification and dimensions in this catalog are subject to change without notice.

POWER RELAY SELECTION CHART

Type	HF115F-T/TH	HF115F-H	HF115F-I
Appearance			
Dimensions(L x W x H) mm	29.0 x 12.7 x 15.7	29.0 x 12.7 x 15.7	29.0 x 12.7 x 15.7
Features	<ul style="list-style-type: none"> • High temperature: 105°C • 5kV dielectric strength (between coil and contacts) • Creepage distance: 10mm • Meet VDE0700/0631 • Product in accordance to IEC 60335-1 available 	<ul style="list-style-type: none"> • High sensitive: 0.25W • 5kV dielectric strength (between coil and contacts) • Creepage distance: 10mm • Meet VDE0700/0631 • Product in accordance to IEC 60335-1 available 	<ul style="list-style-type: none"> • High inrush: TV-5 80A(at 120VAC) • 5kV dielectric strength (between coil and contacts) • Creepage distance: 10mm • Meet VDE0700/0631 • Product in accordance to IEC 60335-1 available
Contact Ratings			
Contact Form	1A, 1C	1A, 1B, 1C	1A, 1C
Contact Material	AgSnO ₂ , AgNi, AgCdO	AgSnO ₂ , AgNi, AgCdO	AgSnO ₂
Max. Switching Current (Res. load)			
Max. Switching Voltage	440VAC / 300VDC	440VAC / 300VDC	440VAC / 300VDC
Max. Switching Power	HF115F-T: 4000VA HF115F-TH: 2500VA	2500VA	4000VA
Rated Load (Resistive load)	HF115F-T: 16A 250VAC HF115F-TH: 10A 250VAC	10A 250VAC	1A: 16A 250VAC
Coil Ratings			
Rated Voltage	5VDC to 60VDC	5VDC to 60VDC	5VDC to 110VDC
Nominal Operating Power	0.25W, 0.4W	0.25W	0.4W
Specifications			
Insulation Resistance	1000MΩ	1000MΩ	1000MΩ
Dielectric Strength (Between coil and contacts)	5000VAC	5000VAC	5000VAC
Ambient Temperature	-40°C to 105°C	-40°C to 85°C	-40°C to 85°C
Operate / Release Time max.	15ms / 8ms	15ms / 8ms	15ms / 8ms
Mechanical Endurance min.	1 x 10 ⁷ OPS	1 x 10 ⁷ OPS	1 x 10 ⁷ OPS
Electrical Endurance min.	1 x 10 ⁵ OPS	1 x 10 ⁵ OPS	7.5 x 10 ⁴ OPS
Layout (Bottom view)			
Terminal Type	PCB	PCB	PCB
Approved Standards	UL/CUL VDE CQC	UL/CUL VDE CQC	UL/CUL VDE CQC
File No.	E134517 116934 CQC08002028130	E134517 116934 CQC08002028130	E134517 116934 CQC08002028130
Cross Reference	SCHRACK: RTH105 16A P&B: RT FUJITSU: FTR-K1	SCHRACK: RT1 Sensitive P&B: RT FUJITSU: FTR-K1	SCHRACK: RT1 Inrush P&B: RT FUJITSU: FTR-H1
Page	220	223	226

Note: Specification and dimensions in this catalog are subject to change without notice.

POWER RELAY SELECTION CHART

Type	HF115F-Q	HF115F-S	HF115F-L
Appearance			
Dimensions(L x W x H) mm	Vertical: (41.0 x 12.7 x 15.7) Horizontal: (45.0 x 12.7 x 15.7)	29.0 x 12.7 x 15.7	29.0 x 12.7 x 15.7
Features	<ul style="list-style-type: none"> Ambient temperature up to 125°C 5kV dielectric strength (between coil and contacts) Creepage distance >8mm Meet VDE0700/0631 UL94, V-0 flammability class Product in accordance to IEC 60335-1 available 	<ul style="list-style-type: none"> Special contact struction Incandescent lamp load: 3000W 230VAC Inrush current: 165A/20ms, 800A/200µs 5kV dielectric strength (between coil and contacts) Creepage distance: 10mm Product in accordance to IEC 60335-1 available Plastic sealed and flux proofed types available 	<ul style="list-style-type: none"> Latching relay 20A switching capability 5kV dielectric strength (between coil and contacts) Creepage distance: 11mm-NO/10mm-CO version Meeting VDE 0700, 0631 reinforce insulation Product in accordance to IEC 60335-1 available

Contact Ratings

Contact Form	1A, 1B	1A	1A, 1C	2A, 2C
Contact Material	AgSnO ₂ , AgNi	W+AgSnO ₂	AgSnO ₂	
Max. Switching Current (Res. load)	20A	16A	16A (1C)	8A (2C)
Max. Switching Voltage	440VAC / 300VDC	440VAC	440VAC / 300VDC	
Max. Switching Power	5000VA	4000VA	4000VA	2000VA
Rated Load (Resistive load)	20A 250VAC	Resistive: 16A 250VAC Incandescent Lamp: 3000W 230VAC Inrush current: 165A / 20ms flourescent: 800A/200µs	16A 250VAC	8A 250VAC

Coil Ratings

Rated Voltage	5VDC to 60VDC	5VDC to 110VDC	5VDC to 24VDC
Nominal Operating Power	0.4W	0.4W	0.4W, 0.6W

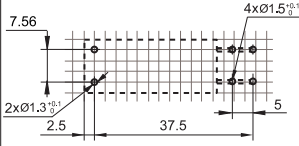
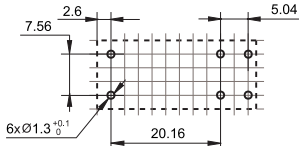
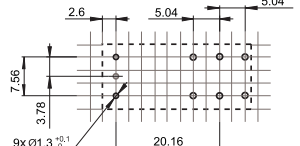

Specifications

Insulation Resistance	1000MΩ	1000MΩ	1000MΩ
Dielectric Strength (Between coil and contacts)	5000VAC	5000VAC	5000VAC
Ambient Temperature	-40°C to 125°C	-40°C to 85°C	-40°C to 85°C
Operate / Release Time max.	15ms / 8ms	15ms / 8ms	10ms / 10ms
Mechanical Endurance min.	1 x 10 ⁷ OPS	5 x 10 ⁶ OPS	2 x 10 ⁶ OPS
Electrical Endurance min.	3 x 10 ⁴ OPS	1 x 10 ⁴ OPS (at 3000W 230VAC)	5 x 10 ⁴ OPS

Layout (Bottom view)			
Terminal Type	PCB, QC	PCB	PCB
Approved Standards	UL/CUL VDE CQC	UL/CUL VDE CQC	UL/CUL VDE CQC
File No.	E134517 116934 CQC08002028130	E134517 116934 CQC08002028130	E134517 116934 CQC17002176310
Cross Reference	SCHRACK: RF/41063 125°C	TE: RTS3T	PANASONIC: DJ SCHRACK: RT1 bistable FUJITSU: FTR-K1L
Page	229	232	234

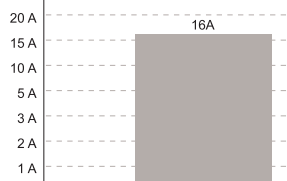
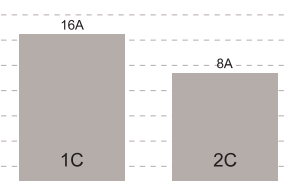
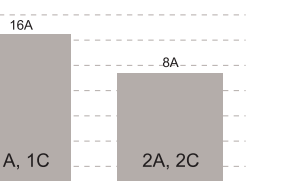
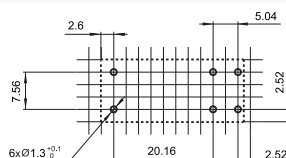
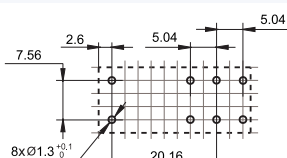
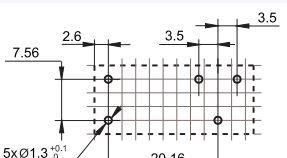

Note: Specification and dimensions in this catalog are subject to change without notice.

POWER RELAY SELECTION CHART

Type	HF115F-LS	HF115FP	HF115FK
Appearance			
Dimensions(L x W x H) mm	29.0 x 12.7 x 15.7	29.0 x 13.0 x 25.5	29.0 x 12.7 x 15.7
Features	<ul style="list-style-type: none"> • Latching relay • Incandescent lamp load: 3500W 277VAC • 5kV dielectric strength (between coil and contacts) • Creepage distance: 11mm • Low height: 15.7 mm • Meeting reinforce insulation 	<ul style="list-style-type: none"> • Manual test device, Type with mechanical indicator / electrical indicator • 5kV dielectric strength (between coil to contacts) • Creepage distance: 8mm • Meet VDE0700/0631 • Sockets available 	<ul style="list-style-type: none"> • Low height: 15.7 mm • 16A switching capability • 5kV dielectric strength (between coil and contacts) • Creepage distance: 10mm • Meeting reinforce insulation • Product in accordance to IEC 60335-1 available
Contact Ratings			
Contact Form	1A	1C 2C	1A, 1C 2A, 2C
Contact Material	W + AgSnO ₂	AgNi	AgSnO ₂
Max. Switching Current (Res. load)			
Max. Switching Voltage	440VAC	440VAC	400VAC
Max. Switching Power	4000VA	4000VA 2000VA	3000VA/4000VA 2000VA
Rated Load (Resistive load)	16A 250VAC	16A 250VAC 8A 250VAC	12A/16A 250VAC 8A 250VAC
Coil Ratings			
Rated Voltage	5VDC to 24VDC	24VAC to 230VAC / 12VDC to 110VDC	5VDC to 48VDC
Nominal Operating Power	0.4W, 0.6W	0.75VA, 0.4W	0.4W
Specifications			
Insulation Resistance	1000MΩ	1000MΩ	1000MΩ
Dielectric Strength (Between coil and contacts)	5000VAC	5000VAC	5000VAC
Ambient Temperature	-40°C to 85°C	-40°C to 70°C	-40°C to 85°C
Operate / Release Time max.	10ms / 10ms	15ms / 15ms (DC)	10ms / 5ms
Mechanical Endurance min.	2 x 10 ⁶ OPS	DC type: 5 x 10 ⁶ OPS AC type: 1 x 10 ⁶ OPS	1 x 10 ⁷ OPS
Electrical Endurance min.	6 x 10 ³ OPS	3 x 10 ⁴ OPS	5 x 10 ⁴ OPS
Layout (Bottom view)			
Terminal Type	PCB	PCB	PCB
Approved Standards	UL/CUL VDE CQC	UL/CUL VDE	UL/CUL VDE CQC
File No.	E134517 116934 CQC14002104529	E133481 116934	E134517 116934 CQC13002103948
Cross Reference	TE: RTX/RTS3T	SCHRACK: XT	OMRON: G2RL FUJITSU: FTR-K1 PANASONIC: LZ SCHRACK: RZ
Page	240	243	246

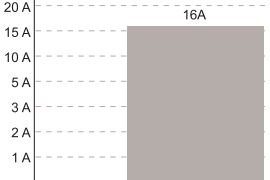
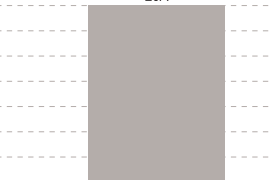
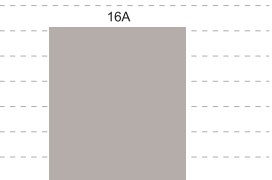
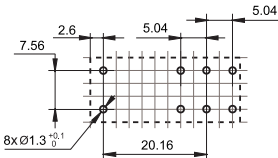
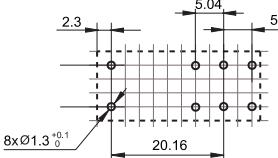
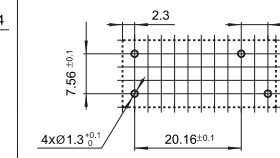

Note: Specification and dimensions in this catalog are subject to change without notice.

POWER RELAY SELECTION CHART

Type	HF115FK-T	HF158F	HF158F-V
Appearance			
Dimensions(L x W x H) mm	29.0 x 12.7 x 15.7	29.0 x 12.7 x 15.7	29.0 x 12.7 x 20.0
Features	<ul style="list-style-type: none"> • High temperature: 105°C • Low height: 15.7 mm • 16A switching capability • 5kV dielectric strength (between coil and contacts) • Creepage distance: 10mm • Meeting reinforce insulation • Sockets available 	<ul style="list-style-type: none"> • 20A switching capability • Low height: 12.5 mm • 5kV dielectric strength (between coil and contacts) • Creepage distance: 10mm • Product in accordance to IEC 60335-1 available 	<ul style="list-style-type: none"> • 10A 300VDC high-voltage switching capability • 5kV dielectric strength (between coil and contacts) • Creepage distance: 10mm • Product in accordance to IEC60335-1 available
Contact Ratings			
Contact Form	1A 1C	1A, 1C	1A
Contact Material	AgSnO ₂	AgSnO ₂ , AgNi	AgSnO ₂
Max. Switching Current (Res. load)			
Max. Switching Voltage	400VAC	440VAC	420VDC/300VAC
Max. Switching Power	4000VA	5000VA	3000W/3324VA
Rated Load (Resistive load)	16A 250VAC	16A 250VAC	10A 300VDC 12A 277VAC
Coil Ratings			
Rated Voltage	5VDC to 48VDC	5VDC to 48VDC	5VDC to 24VDC
Nominal Operating Power	0.4W	0.4W	0.4W
Specifications			
Insulation Resistance	1000MΩ	1000MΩ	1000MΩ
Dielectric Strength (Between coil and contacts)	5000VAC	5000VAC	5000VAC
Ambient Temperature	-40°C to 105°C	-40°C to 85°C	-40°C to 85°C
Operate / Release Time max.	10ms / 5ms	15ms / 8ms	10ms / 5ms
Mechanical Endurance min.	1 x 10 ⁷ OPS	2 x 10 ⁷ OPS	2 x 10 ⁶ OPS
Electrical Endurance min.	3 x 10 ⁴ OPS	1 x 10 ⁵ OPS	1 x 10 ⁴ OPS
Layout (Bottom view)			
Terminal Type	PCB	PCB	PCB
Approved Standards	UL/CUL VDE CQC	UL/CUL VDE	UL/CUL VDE CQC
File No.	E134517 116934 CQC13002103948	E134517 40032833 CQC15002129497	E134517 40032833 CQC15002129497
Cross Reference	P&B: RT SCHRACK:RZ FUJITSU: FTR-K1	OMRON: G2RL SCHRACK: RT PANASONIC: LZ RELPOL: RM85 FINDER: 41 SERIES FUJITSU: FTR-K1	
Page	250	253	256

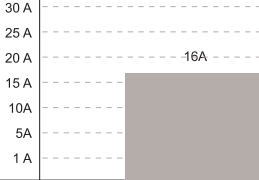
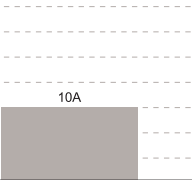
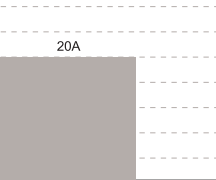
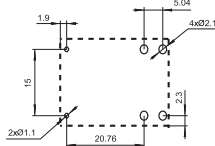
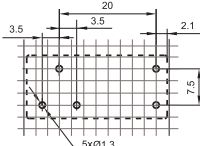
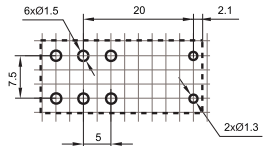

Note: Specification and dimensions in this catalog are subject to change without notice.

POWER RELAY SELECTION CHART

Type	HF175F	HF14FF	HF14FW
Appearance			
Dimensions(L x W x H) mm	29.0 x 19.6 x 15.7	29.0 x 13.0 x 26.0	29.0 x 13.0 x 26.5
Features	<ul style="list-style-type: none"> • 2 Form A and 2 Form C configurations • Low height, only 15.7mm • 5kV dielectric strength (between coil and contacts) • Creepage/clearance distance > 10mm, Meets reinforce insulation • Product in accordance to IEC 60335-1 available • UL insulation system: Class F 	<ul style="list-style-type: none"> • 10A switching capability • 5kV dielectric strength (between coil and contacts) • 1 Form A and 1 Form C configurations • Plastic sealed and flux proofed types available 	<ul style="list-style-type: none"> • 20A switching capability • 4kV dielectric strength (between coil and contacts) • Plastic sealed and flux proofed types available
Contact Ratings			
Contact Form	2A, 2C	1A, 1C	1A, 1B, 1C
Contact Material	AgSnO ₂	AgSnO ₂ , AgNi, AgCdO	AgSnO ₂ , AgCdO
Max. Switching Current (Resistive load)			
Max. Switching Voltage	277VAC	277VAC / 30VDC	277VAC / 30VDC
Max. Switching Power	4432VA	2770VA / 300W	5540VA / 480W
Rated Load (Resistive load)	16A 277VAC	10A 277VAC/30VDC TV-5 120VAC	Resistive: 16A 277VAC/24VDC Motor: 1HP 240VAC TV-8 125VAC (NO contact)
Coil Ratings			
Rated Voltage	5VDC to 48VDC	3VDC to 60VDC	5VDC to 110VDC
Nominal Operating Power	0.8W	0.53W	0.53W, 0.72W
Specifications			
Insulation Resistance	1000MΩ	1000MΩ	1000MΩ
Dielectric Strength (Between coil and contacts)	5000VAC	5000VAC	4000VAC
Ambient Temperature	-40°C to 85°C	-40°C to 70°C	-40°C to 85°C
Operate / Release Time max.	10ms / 5ms	15ms / 5ms	15ms / 5ms
Mechanical Endurance min.	5 x 10 ⁶ OPS	1 x 10 ⁷ OPS	1 x 10 ⁷ OPS
Electrical Endurance min.	5 x 10 ⁴ OPS	1 x 10 ⁵ OPS	1 x 10 ⁵ OPS
Layout (Bottom view)			
Terminal Type	PCB	PCB	PCB
Approved Standards	UL/CUL TÜV CQC	UL/CUL TÜV CQC	UL/CUL VDE CQC
File No.	E133481 R50412801 CQC18002196447 CQC18002202622	E134517 R50140759 CQC10002046169	E134517 40023508 CQC10002046170
Cross Reference		OMRON: G2R PANASONIC: JR1/JR1A FUJITSU: VS NEC: CH P&B: RKA/RKS	OMRON: G2R PANASONIC: JR1AF FUJITSU: FBR610 P&B: RKA/RKS
Page	259	262	265



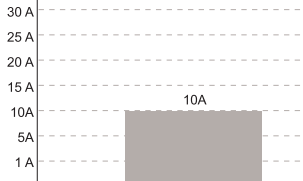
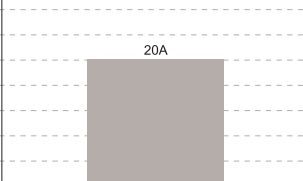
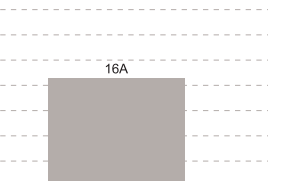
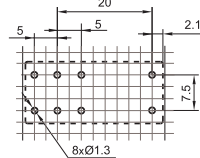
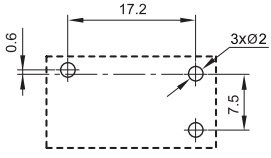
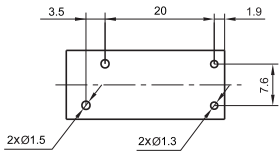

Note: Specification and dimensions in this catalog are subject to change without notice.

POWER RELAY SELECTION CHART

Type	HF140FF	HF25F	HF62F
Appearance			
Dimensions(L x W x H) mm	29.0 x 13.0 x 26.3	22.8 x 12.3 x 24.4	29.0 x 12.6 x 24.4
Features	<ul style="list-style-type: none"> • 10A switching capability • 5kV dielectric strength (between coil and contacts) • 2.0mm contact gap available • Plastic sealed and flux proofed types available 	<ul style="list-style-type: none"> • 20A switching capability • 5kV impulse withstand voltage (between coil and contacts) • small and for microwave oven • PCB & QC layouts • Flux proofed types available 	<ul style="list-style-type: none"> • 20A switching capability • 5kV dielectric strength (between coil and contacts) • 10kV impulse withstand voltage (between coil and contacts) • creepage distance: 8mm
Contact Ratings			
Contact Form	2A, 2C	1A	1A
Contact Material	AgSnO ₂ , AgNi, AgCdO	AgSnO ₂	AgSnO ₂
Max. Switching Current (Resistive load)			
Max. Switching Voltage	250VAC / 30VDC	250VAC / 30VDC	277VAC / 30VDC
Max. Switching Power	2500VA / 240W	5000VA / 480W	4000VA / 480W
Rated Load (Resistive load)	5A 250VAC 10A 250VAC 8A 30VDC	20A 250VAC Motor:1.5HP 250VAC	16A 250VAC/30VDC
Coil Ratings			
Rated Voltage	3VDC to 110VDC	5VDC to 24VDC	5VDC to 48VDC
Nominal Operating Power	0.53W, 0.8W, 1.4W	0.5W	0.54W
Specifications			
Insulation Resistance	1000MΩ	1000MΩ	1000MΩ
Dielectric Strength (Between coil and contacts)	5000VAC	5000VAC	5000VAC
Ambient Temperature	-40°C to 85°C	-40°C to 85°C	-40°C to 85°C
Operate / Release Time max.	15ms / 5ms	15ms / 5ms	20ms / 10ms
Mechanical Endurance min.	Standard: 1 x 10 ⁷ OPS W Type(1.5mm):5 x 10 ⁵ OPS W Type(2.0mm):3 x 10 ⁵ OPS	2 x 10 ⁶ OPS	1 x 10 ⁷ OPS
Electrical Endurance min.	Standard: 1 x 10 ⁵ OPS W Type(1.5mm):1 x 10 ³ OPS W Type(2.0mm):3 x 10 ³ OPS	1 x 10 ⁵ OPS	1 x 10 ⁵ OPS
Layout (Bottom view)			
Terminal Type	PCB	PCB, QC	PCB, QC
Approved Standards	UL/CUL TÜV CQC	UL/CUL VDE TÜV CQC	UL/CUL TÜV CQC
File No.	E134517 R50149131 CQC09002030294	E134517 40026917 R50207576 CQC09002028692	E133481 R50147086 CQC09002028470
Cross Reference	OMRON: G2R/G2RG PANASONIC: JR2/JR2A FUJITSU: FBR-F1/VSB NEC: TP P&B: RKA/RKS	OMRON: G5G PANASONIC: LE	OMRON: G5J PANASONIC: JR1AF-TMP FUJITSU: VR OEG: OMIF
Page	268	272	276



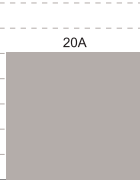
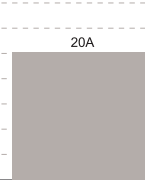

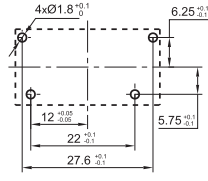
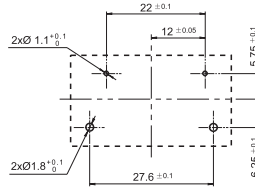
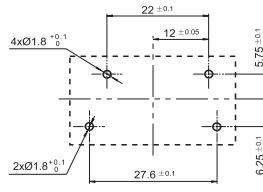
Note: Specification and dimensions in this catalog are subject to change without notice.

POWER RELAY SELECTION CHART

Type	HF102F	HF161F	HF161F-W
Appearance			
Dimensions(L x W x H) mm	30.5 x 16.0 x 23.5	30.4 x 15.9 x 23.3	30.4 x 15.9 x 23.3
Features	<ul style="list-style-type: none"> • Heavy load up to 5000VA • Ideal for motor switching • Withstand inrush current of 80A • PCB & QC layouts available 	<ul style="list-style-type: none"> • 4.5kV dielectric strength (between coil and contacts) • Heavy load up to 6250VA • Ideal for motor switching • PCB layouts available 	<ul style="list-style-type: none"> • 31A switching capitable • Applicable to inverter used for photovoltaic power generation systems • Ideal for UPS • 1.5mm contact gap (compliant to European Photovoltaic Standard VDE0126) • The clearance distance between contact and coil is bigger than 6.4mm, the creepage distance is bigger than 8mm.
Contact Ratings			
Contact Form	1A	1A	1A
Contact Material	AgSnO ₂ , AgCdO	AgSnO ₂ , AgCdO	AgSnO ₂
Max. Switching Current (Resistive load)			
Max. Switching Voltage	250VAC	250VAC	277VAC
Max. Switching Power	6250VA	6250VA	7750VA
Rated Load (Resistive load)	20A 250VAC Motor: 2HP 240VAC	20A 250VAC Motor: 2HP 240VAC	Resistive: 26A 250VAC Inductive: 31A 250VAC
Coil Ratings			
Rated Voltage	5VDC to 48VDC	5VDC to 48VDC	9VDC to 24VDC
Nominal Operating Power	0.9W	0.9W	1.4W
Specifications			
Insulation Resistance	1000MΩ	1000MΩ	1000MΩ
Dielectric Strength (Between coil and contacts)	4500VAC	4500VAC	4500VAC
Ambient Temperature	-25°C to 85°C	-40°C to 85°C	-40°C to 85°C (Apply holding voltage to coil, which is 45% to 80% that of rated voltage)
Operate / Release Time max.	20ms / 10ms	20ms / 10ms	20ms / 10ms
Mechanical Endurance min.	2 x 10 ⁶ OPS	2 x 10 ⁶ OPS	1 x 10 ⁶ OPS
Electrical Endurance min.	1 x 10 ⁵ OPS	1 x 10 ⁵ OPS	3 x 10 ⁴ OPS
Layout (Bottom view)			
Terminal Type	PCB, QC	PCB	PCB
Approved Standards	UL/CUL VDE CQC	UL/CUL VDE CQC	UL/CUL VDE CQC
File No.	E134517 40024142 CQC13002098165	E134517 40031410 CQC10002050943	E134517 40031410 CQC10002050943
Cross Reference	OMRON: G4A PANASONIC: LF OEG: PCFN	OMRON: G4A PANASONIC: LF OEG: PCFN	PANASONIC: LF-G OEG: PCFN SOLAR
Page	279	282	285

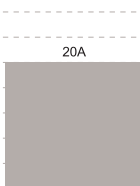

Note: Specification and dimensions in this catalog are subject to change without notice.

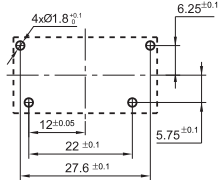
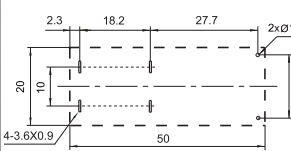
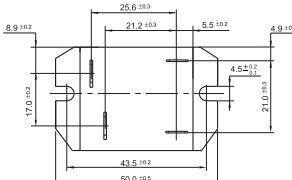
POWER RELAY SELECTION CHART

Type	HF160F	HF166F	HF37F
Appearance			
Dimensions(L x W x H) mm	30.4 x 15.9 x 25.4	50.0 x 27.0 x 20.0	35.2 x 32.2 x 24.0
Features	<ul style="list-style-type: none"> • 4.5kV dielectric strength (between coil and contacts) • Heavy load up to 6250VA • Ideal for motor switching • PCB & QC layouts 	<ul style="list-style-type: none"> • Latching relay • 4mm contact gap available • 25A switching capability • 5kV dielectric strength (between coil and contacts) • Creepage distance between coil and contacts:10mm 	<ul style="list-style-type: none"> • 30A switching capability • 1 Form A configuration • 70A withstands inrush current • TV-15(at 120VAC) available
Contact Ratings			
Contact Form	1A	1A+1B	1A
Contact Material	AgSnO ₂ , AgCdO	AgSnO ₂	AgSnO ₂ , AgCdO
Max. Switching Current (Resistive load)			
Max. Switching Voltage	250VAC	277VAC	277VAC
Max. Switching Power	6250VA	6925VA	7500VA
Rated Load (Resistive load)	20A 250VAC Motor: 2HP 240VAC	25A 277VAC	30A 250VAC
Coil Ratings			
Rated Voltage	5VDC to 48VDC	5VDC to 48VDC	5VDC to 60VDC
Nominal Operating Power	0.9W	1.2W, 2.4W	1.2W
Specifications			
Insulation Resistance	1000MΩ	1000MΩ	1000MΩ
Dielectric Strength (Between coil and contacts)	4500VAC	5000VAC	4000VAC
Ambient Temperature	-40°C to 85°C	-40°C to 85°C	-40°C to 70°C
Operate / Release Time max.	20ms / 10ms	25ms / 25ms	20ms / 5ms
Mechanical Endurance min.	2 x 10 ⁶ OPS	6 x 10 ⁵ OPS	5 x 10 ⁶ OPS
Electrical Endurance min.	1 x 10 ⁵ OPS	3 x 10 ⁴ OPS	1 x 10 ⁵ OPS
Layout (Bottom view)			
Terminal Type	PCB, QC	PCB	QC
Approved Standards	UL/CUL VDE CQC	UL/CUL TÜV	UL/CUL VDE CQC
File No.	E134517 40024142 CQC12002072207	E133481 B130453286009	E134517 40025378 CQC13002102287
Cross Reference	OMRON: G4A PANASONIC: JM FUJITSU: FTR-K3/VH OEG: PCF		FUJITSU: VF
Page	288	291	294

Note: Specification and dimensions in this catalog are subject to change without notice.

POWER RELAY SELECTION CHART

Type	HF170F	HF105F-1	HF105F-2
Appearance			
Dimensions(L x W x H) mm	36.0 x 30.0 x 40.0	32.3 x 27.1 x 20	32.2 x 27.5 x 27.8
Features	<ul style="list-style-type: none"> • 35A switching capability • Applicable to solar photovoltaic inverter • 3.6 mm contact gap • Low coil holding voltage contributes to saving energy of equipment • UL insulation system: Class F 	<ul style="list-style-type: none"> • 40A switching capability • PCB coil terminals, ideal for heavy duty load • 4kV dielectric strength (between coil and contacts) • Heavy load up to 7200VA • Unenclosed, plastic sealed and dust protected types available 	<ul style="list-style-type: none"> • 40A switching capability • PCB coil terminals, ideal for heavy duty load • Heavy load up to 7200VA • Plastic sealed and dust protected types available

Contact Ratings

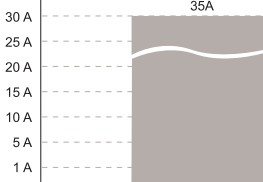
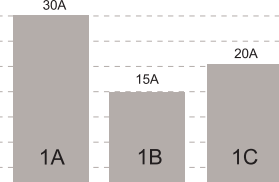
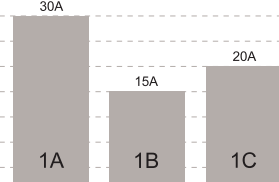
Contact Form	2A	1A, 1B, 1C	1A, 1B, 1C
Contact Material	AgSnO ₂ , AgNi	AgSnO ₂ , AgCdO	AgSnO ₂ , AgCdO
Max. Switching Current (Resistive load)			
Max. Switching Voltage	277VAC	277VAC / 28VDC	277VAC / 28VDC
Max. Switching Power	9695VA	7200VA / 560W	7200VA / 560W
Rated Load (Resistive load)	35A 277VAC	1A: 30A 240VAC/20A 28VDC 1B: 15A 240VAC/10A 28VDC 1C: 20A/10A 240VAC/28VDC L Type(1A): 25A 240VAC/20A 28VDC	1A: 30A 240VAC/20A 28VDC 1B: 15A 240VAC/10A 28VDC 1C: 20A/10A 240VAC/28VDC L Type(1A): 25A 240VAC/20A 28VDC

Coil Ratings

Rated Voltage	6VDC to 48VDC	12VAC to 277VAC / 5VDC to 110VDC	12VAC to 277VAC / 5VDC to 110VDC
Nominal Operating Power	1.88W	2.0VA, 0.9W	2.0VA, 0.9W

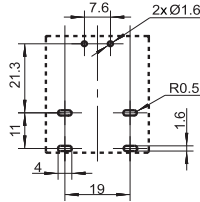
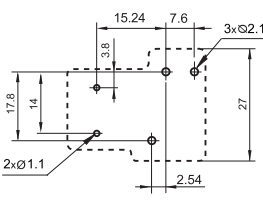
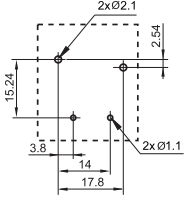

Specifications

Insulation Resistance	1000MΩ	1000MΩ	1000MΩ
Dielectric Strength (Between coil and contacts)	5000VAC	2500VAC / 4000VAC	2500VAC
Ambient Temperature	-40°C to 85°C	DC: -55°C to 85°C AC: -55°C to 60°C	DC: -55°C to 85°C AC: -55°C to 60°C
Operate / Release Time max.	30ms / 10ms	15ms / 10ms(DC type)	15ms / 10ms(DC type)
Mechanical Endurance min.	1 x 10 ⁶ OPS	1 x 10 ⁷ OPS	1 x 10 ⁷ OPS
Electrical Endurance min.	3 x 10 ⁴ OPS	1 x 10 ⁵ OPS	1 x 10 ⁵ OPS

Layout (Bottom view)			
Terminal Type	PCB	PCB	PCB, QC
Approved Standards	UL/CUL TÜV CQC	UL/CUL VDE CQC	UL/CUL VDE CQC
File No.	E133481 R50384178 CQC17002175164	E134517 40025518(DC Type) CQC09002031229(Ningbo Factory, DC Type) CQC12002071130(Ningbo Factory, AC Type)	E134517 40025518(DC Type) CQC10002049165(DC Type) CQC16002140270(Hong Yuanda Factory, DC Type)
Cross Reference	PANASONIC: HES	OMRON: G8P PANASONIC: JTN/JTV OEG: ORU P&B: T9A/T90	OMRON: G7G/G8P PANASONIC: JT OEG: ORU P&B: 491/T9A
Page	307	309	315

Note: Specification and dimensions in this catalog are subject to change without notice.

POWER RELAY SELECTION CHART

Type	HF105F-4	HF105F-5	HF2100
Appearance			
Dimensions(L x W x H) mm	50.0 x 27.2 x 27.8	32.4 x 27.3 x 27.8	32.0 x 27.5 x 28.0
Features	<ul style="list-style-type: none"> • 40A switching capability • 2.5kV dielectric strength (between coil and contacts) • Heavy load up to 7200VA • Plastic sealed and dust protected types available 	<ul style="list-style-type: none"> • 40A switching capability • PCB coil terminals, ideal for heavy duty load • Heavy load up to 7200VA • 4kV dielectric strength (between coil and contacts) • Plastic sealed and dust protected types available 	<ul style="list-style-type: none"> • PCB coil terminals, ideal for heavy duty load • 2.5kV dielectric strength (between coil and contacts) • Plastic sealed and flux proofed types available

Contact Ratings

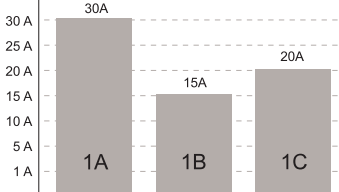
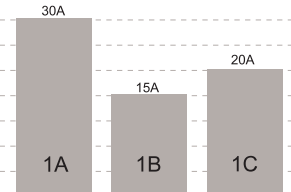
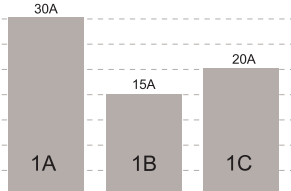
Contact Form	1A, 1B, 1C	1A, 1B, 1C	1A, 1B, 1C
Contact Material	AgSnO ₂ , AgCdO	AgSnO ₂ , AgCdO	AgSnO ₂ , AgCdO
Max. Switching Current (Resistive load)			
Max. Switching Voltage	277VAC / 28VDC	277VAC / 28VDC	277VAC / 30VDC
Max. Switching Power	7200VA / 560W	7200VA / 560W	7200VA / 600W
Rated Load (Resistive load)	1A: 30A 240VAC/20A 28VDC 1B: 15A 240VAC/10A 28VDC 1C: 20A/10A 240VAC/28VDC L Type(1A): 25A 240VAC/20A/28VDC	1A: 30A 240VAC/20A 28VDC 1B: 15A 240VAC/10A 28VDC 1C: 20A/10A 240VAC/28VDC L Type(1A): 25A 240VAC/20A/28VDC	1A: 30A 240VAC/20A 30VDC 1B: 15A 240VAC/10A 30VDC 1C: 20A/10A 240VAC/30VDC

Coil Ratings

Rated Voltage	12VAC to 277VAC / 5VDC to 110VDC	12VAC to 277VAC / 5VDC to 110VDC	5VDC to 110VDC
Nominal Operating Power	2.0VA, 0.9W	2.0VA, 0.9W	0.9W

Specifications

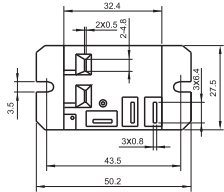
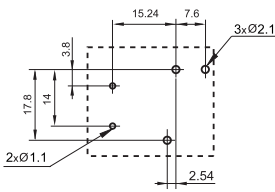
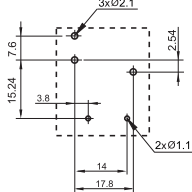

Insulation Resistance	1000MΩ	1000MΩ	1000MΩ
Dielectric Strength (Between coil and contacts)	2500VAC	4000VAC / 2500VAC	2500VAC
Ambient Temperature	DC: -55°C to 85°C AC: -55°C to 60°C	DC: -55°C to 85°C AC: -55°C to 60°C	-55°C to 85°C
Operate / Release Time max.	15ms / 10ms(DC type)	15ms / 10ms(DC type)	15ms / 10ms
Mechanical Endurance min.	1 x 10 ⁷ OPS	1 x 10 ⁷ OPS	1 x 10 ⁷ OPS
Electrical Endurance min.	1 x 10 ⁵ OPS	1 x 10 ⁵ OPS	1 x 10 ⁵ OPS (at 30A 240VAC)

Layout (Bottom view)			
----------------------	-------------------------------------------------------------------------------------	--------------------------------------------------------------------------------------	---------------------------------------------------------------------------------------

Terminal Type	QC	PCB, QC	PCB, QC
Approved Standards	UL/CUL VDE CQC	UL/CUL VDE CQC	UL/CUL TÜV CQC
File No.	E134517 40025518(DC Type) CQC09002031229(DC Type)	E134517 40025518(DC Type) CQC10002049165(DC Type) CQC16002140270(Hong Yuanda Factory,DC Type)	E134517 R50153835 CQC10002049166
Cross Reference	OMRON: G7G/G8P PANASONIC: JT OEG: ORU P&B: T9A	OMRON: G7G/G8P PANASONIC: JTN OEG: ORU P&B: T90/T9A	OMRON: G7G PANASONIC: JT P&B: 491/T9A ZETTLER: AZ2100
Page	319	323	327

Note: Specification and dimensions in this catalog are subject to change without notice.

POWER RELAY SELECTION CHART

Type	HF2110 / HF2120	HF2150 / HF2151	HF2160
Appearance			
Dimensions(L x W x H) mm	28.4 x 23.5 x 15.3	31.8 x 27.0 x 19.1	32.0 x 27.5 x 19.8
Features	<ul style="list-style-type: none"> • 30A switching capability • 2.5kV dielectric strength (between coil and contacts) • Plastic sealed and flux proofed types available 	<ul style="list-style-type: none"> • 30A switching capability • 2.5kV dielectric strength (between coil and contacts) • Heavy load up to 7200VA • Plastic sealed and flux proofed type available 	<ul style="list-style-type: none"> • 30A switching capability • PCB coil terminals, ideal for heavy duty load • 2.5KV dielectric strength (between coil and contacts) • Plastic sealed and Dust proofed types available

Contact Ratings

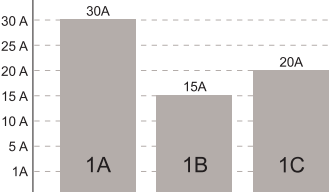
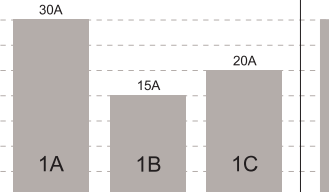
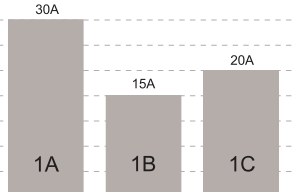
Contact Form	1A, 1B, 1C	1A, 1B, 1C	1A, 1B, 1C
Contact Material	AgSnO ₂ , AgCdO	AgSnO ₂ , AgCdO	AgSnO ₂ , AgCdO
Max. Switching Current (Resistive load)			
Max. Switching Voltage	277VAC / 30VDC	277VAC / 30VDC	277VAC / 30VDC
Max. Switching Power	7200VA / 600W	7200VA / 600W	7200VA / 600W
Rated Load (Resistive load)	1A: 30A 240VAC/20A 30VDC 1B: 15A 240VAC/10A 30VDC 1C: 20A/10A 240VAC/30VDC	1A: 30A 240VAC/20A 30VDC 1B: 15A 240VAC/10A 30VDC 1C: 20A/10A 240VAC/30VDC	1A: 30A 240VAC/20A 30VDC 1B: 15A 240VAC/10A 30VDC 1C: 20A/10A 240VAC/30VDC

Coil Ratings

Rated Voltage	5VDC to 110VDC	5VDC to 110VDC	5VDC to 110VDC
Nominal Operating Power	0.9W	0.9W	0.9W

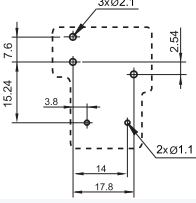
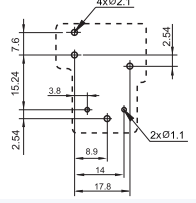
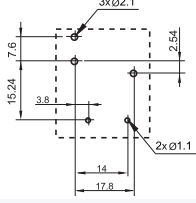

Specifications

Insulation Resistance	1000MΩ	1000MΩ	1000MΩ
Dielectric Strength (Between coil and contacts)	2500VAC	2500VAC	2500VAC
Ambient Temperature	-55°C to 85°C	-55°C to 85°C	-55°C to 85°C
Operate / Release Time max.	15ms / 10ms	15ms / 10ms	15ms / 10ms
Mechanical Endurance min.	1 x 10 ⁷ OPS	1 x 10 ⁷ OPS	1 x 10 ⁷ OPS
Electrical Endurance min.	1 x 10 ⁵ OPS (at 30A 240VAC)	1 x 10 ⁵ OPS (at 30A 240VAC)	1 x 10 ⁵ OPS (at 30A 240VAC)

Layout (Bottom view)			
Terminal Type	PCB, QC	PCB	PCB, QC
Approved Standards	UL/CUL CQC	UL/CUL TÜV CQC	UL/CUL TÜV CQC
File No.	E134517 CQC10002049166	E134517 R50153835 CQC10002049166	E134517 R50153835 CQC10002049166
Cross Reference	OMRON: G7G PANASONIC: JT NEC: CT P&B: 491/T90 ZETTLER: AZ2110/AZ2120	OMRON: G7G PANASONIC: JTN/JTV NEC: CT P&B: T9A/T90 ZETTLER: AZ2150/AZ2151	PANASONIC: JT NEC: CT P&B: T9A/T90 ZETTLER: AZ2160
Page	331	337	341

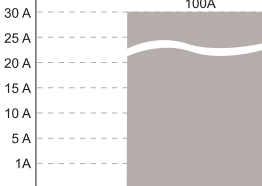
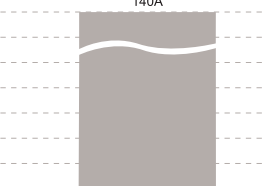
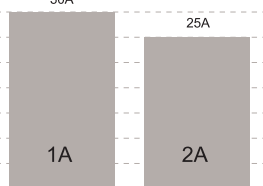
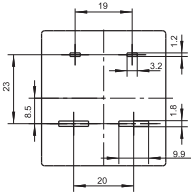
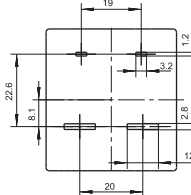
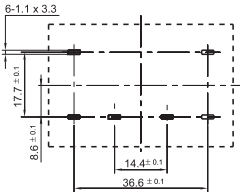

Note: Specification and dimensions in this catalog are subject to change without notice.

POWER RELAY SELECTION CHART

Type	HF172F-100	HF172F-140	HF116F-1
Appearance			
Dimensions(L x W x H) mm	45.0 x 41.3 x 43	45.0 x 41.4 x 43	50.5 x 32.9 x 36.0
Features	<ul style="list-style-type: none"> • 100A switching capability • Applicable to solar photovoltaic inverter • 4.0 mm contact gap • Low coil holding voltage contributes to saving energy of equipment • UL insulation system: Class F 	<ul style="list-style-type: none"> • 140A switching capability • Applicable to solar photovoltaic inverter • 3.0 mm contact gap • Low coil holding voltage contributes to saving energy of equipment • UL insulation system: Class F 	<ul style="list-style-type: none"> • 30A switching capability • 4kV dielectric strength (between coil and contacts) • Heavy load up to 8310VA • 3mm contact gap available
Contact Ratings			
Contact Form	1A	1A	1A, 2A
Contact Material	AgNi	AgNi	AgSnO ₂ , AgCdO
Max. Switching Current (Resistive load)	 <p>100A</p>	 <p>140A</p>	 <p>30A, 25A</p> <p>1A, 2A</p>
Max. Switching Voltage	800VAC	800VAC	277VAC
Max. Switching Power	24000VA	24000VA	8310VA
Rated Load (Resistive load)	Making 30A, carrying 100A, breaking 30A 690VAC 85°C	Making 30A, carrying 140A, breaking 30A 400VAC 85°C	1A: 30A 240VAC/30A 277VAC 2A: 25A 240VAC/25A 277VAC
Coil Ratings			
Rated Voltage	6VDC to 24VDC	6VDC to 24VDC	6VAC to 220/240VAC 3VDC to 200VDC
Nominal Operating Power	2.5W	2.5W	2.7VA, 1.9W
Specifications			
Insulation Resistance	1000MΩ	1000MΩ	1000MΩ
Dielectric Strength (Between coil and contacts)	5000VAC	5000VAC	4000VAC
Ambient Temperature	-40°C to 85°C	-40°C to 85°C	-55°C to 70°C
Operate / Release Time max.	30ms / 10ms	30ms / 10ms	30ms / 30ms
Mechanical Endurance min.	1 x 10 ⁶ OPS	1 x 10 ⁶ OPS	1 x 10 ⁷ OPS
Electrical Endurance min.	3 x 10 ⁴ OPS	3 x 10 ⁴ OPS	1 x 10 ⁵ OPS
Layout (Bottom view)			
Terminal Type	PCB	PCB	PCB, QC, Panel Mount
Approved Standards	UL/CUL TÜV	UL/CUL TÜV	UL/CUL TÜV CQC
File No.	E133481 R50393929	E133481 R50393829	E134517 R50154722 CQC09002031231(DC Type)
Cross Reference	SONGCHUAN:511HP1	SONGCHUAN:511EP	OMRON: G7L PANASONIC: HE
Page	345	347	349

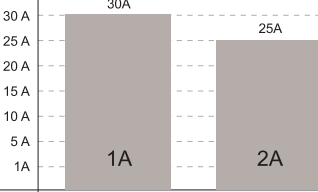
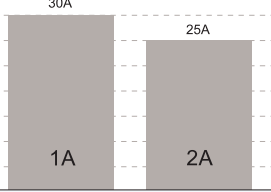
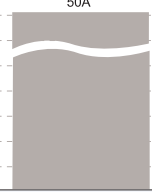
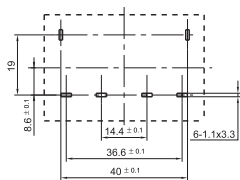
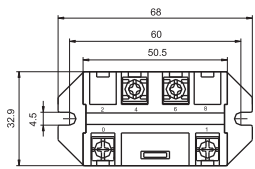
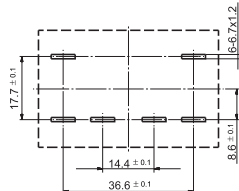

Note: Specification and dimensions in this catalog are subject to change without notice.

POWER RELAY SELECTION CHART

Type	HF116F-2	HF116F-3	HF116F-G
Appearance			
Dimensions(L x W x H) mm	51.5 x 34.9 x 36.0	50.5 x 32.9 x 51.0	51.5 x 34.9 x 36.0
Features	<ul style="list-style-type: none"> • 30A switching capability • 4kV dielectric strength (between coil and contacts) • 3mm contact gap available 	<ul style="list-style-type: none"> • 30A switching capability • 4kV dielectric strength (between coil and contacts) • Heavy load up to 8310VA • 3mm contact gap available 	<ul style="list-style-type: none"> • 50A switching capability • Applicable to inverter used for photovoltaic power generation systems • 4kV dielectric strength (between coil and contacts) • 3mm contact gap (compliant to European Photovoltaic Standard VDE0126, compliant to IEC 62109-2-2011)
Contact Ratings			
Contact Form	1A, 2A	1A, 2A	1A, 2A
Contact Material	AgSnO ₂ , AgCdO	AgSnO ₂ , AgCdO	AgSnO ₂ , AgNi
Max. Switching Current (Resistive load)			
Max. Switching Voltage	277VAC	277VAC	277VAC
Max. Switching Power	8310VA	8310VA	15235VA
Rated Load (Resistive load)	1A: 30A 240VAC/30A 277VAC 2A: 25A 240VAC/25A 277VAC	1A: 30A 240VAC/30A 277VAC 2A: 25A 240VAC/25A 277VAC	50A 277VAC
Coil Ratings			
Rated Voltage	6VAC to 220/240VAC 3VDC to 200VDC	6VAC to 220/240VAC 3VDC to 200VDC	3VDC to 48VDC
Nominal Operating Power	2.7VA, 1.9W	2.7VA, 1.9W	3.2W
Specifications			
Insulation Resistance	1000MΩ	1000MΩ	1000MΩ
Dielectric Strength (Between coil and contacts)	4000VAC	4000VAC	4000VAC
Ambient Temperature	-55°C to 70°C	-55°C to 70°C	-40°C to 85°C
Operate / Release Time max.	30ms / 30ms	30ms / 30ms	30ms / 30ms
Mechanical Endurance min.	1 x 10 ⁷ OPS	1 x 10 ⁷ OPS	1 x 10 ⁶ OPS
Electrical Endurance min.	1 x 10 ⁵ OPS	1 x 10 ⁵ OPS	3 x 10 ⁴ OPS
Layout (Bottom view)			
Terminal Type	PCB, QC, Panel Mount	Screw	PCB
Approved Standards	UL/CUL TÜV CQC	UL/CUL TÜV CQC	UL/CUL TÜV
File No.	E134517 R50154722 CQC09002031231(DC Type)	E134517 R50154722 CQC09002031231(DC Type)	E134517 R50154722
Cross Reference	OMRON: G7L PANASONIC: HE	OMRON: G7L PANASONIC: HE	PANASONIC: HE SONGCHUAN: 510H
Page	353	357	361





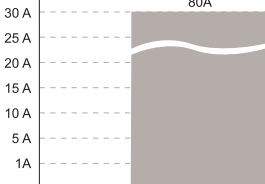
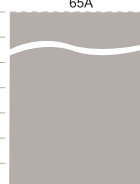
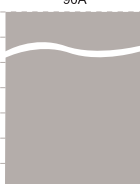
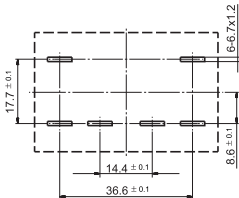
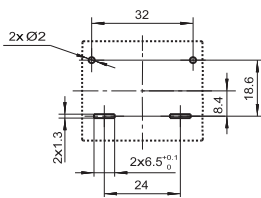
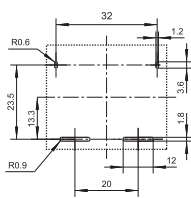

Note: Specification and dimensions in this catalog are subject to change without notice.

POWER RELAY SELECTION CHART

Type	HF116F-80	HF176F	HF167F
Appearance			
Dimensions(L x W x H) mm	50.5 x 32.9 x 36	38.0 x 33.0 x 36.8	38.0 x 33.0 x 39.5
Features	<ul style="list-style-type: none"> • 80A switching capability • Applicable to solar photovoltaic inverter • Applicable to UPS • 3mm contact gap (compliant to European Photovoltaic Standard VDE0126, compliant to IEC 62109-2-2011) • 4kV dielectric strength (between coil and contacts) 	<ul style="list-style-type: none"> • 65A switching capability. • Applicable to solar photovoltaic inverter • 3mm contact gap • Low coil holding voltage contributes to saving energy of equipment. • UL insulation system: Class F 	<ul style="list-style-type: none"> • 90A switching capability • Applicable to solar photovoltaic inverter • 3mm contact gap • Low coil holding voltage contributes to saving energy of equipment • UL insulation system: Class F
Contact Ratings			
Contact Form	1A	1A	1A
Contact Material	AgSnO ₂ , AgNi	AgSnO ₂ , AgNi	AgSnO ₂ , AgNi
Max. Switching Current (Resistive load)			
Max. Switching Voltage	277VAC/60VDC	400VAC	400VAC
Max. Switching Power	24930VA	18005VA	25920VA
Rated Load (Resistive load)	80A 60VDC/80A 250VAC	Making 20A, carrying 65A, breaking 20A 277VAC 85°C	Making 30A, carrying 100A, breaking 30A 400VAC 85°C
Coil Ratings			
Rated Voltage	3VDC to 48VDC	6VDC to 24VDC	6VDC to 24VDC
Nominal Operating Power	3.2W	1.92W	1.92W
Specifications			
Insulation Resistance	1000MΩ	1000MΩ	1000MΩ
Dielectric Strength (Between coil and contacts)	4000VAC	5000VAC 1min	5000VAC
Ambient Temperature	-40°C to 85°C	-40°C to 85°C	-40°C to 85°C
Operate / Release Time max.	30ms / 30ms	30ms / 10ms	30ms / 10ms
Mechanical Endurance min.	1 x 10 ⁶ OPS	1 x 10 ⁶ OPS	1 x 10 ⁶ OPS
Electrical Endurance min.	6 x 10 ³ OPS	3 x 10 ⁴ OPS	3 x 10 ⁴ OPS
Layout (Bottom view)			
Terminal Type	PCB	PCB	PCB
Approved Standards	UL/CUL TÜV	UL/CUL TÜV	UL/CUL TÜV CQC
File No.	E134517 R50154722	E133481 R50411032	E133481 R50360703 CQC17002164558
Cross Reference	PANASONIC: HE SONGCHUAN: 511E	PANASONIC: HE	PANASONIC: HE
Page	365	367	369



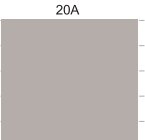

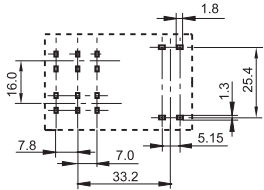
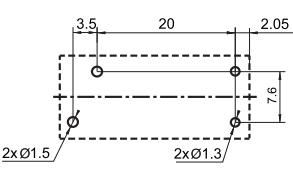
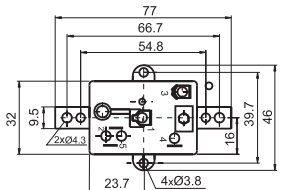
Note: Specification and dimensions in this catalog are subject to change without notice.

POWER RELAY SELECTION CHART

Type	HF92F	HF78F	HF84F
Appearance			
Dimensions(L x W x H) mm	52.0 x 33.7 x 26.7	25.5 x 12.5 x 28.5	47.0 x 32.0 x 28.5
Features	<ul style="list-style-type: none"> • 30A switching capability • Creepage distance: 8mm • 4kV dielectric strength (between coil and contacts) • Plastic sealed and flux proofed types • PCB & QC layouts 	<ul style="list-style-type: none"> • Small and for microwave oven • 20A switching capability • 4.0kV dielectric strength (between coil and contacts) • Low height: 28.5 mm 	<ul style="list-style-type: none"> • 16A switching capability • 2.5kV dielectric strength (between coil and contacts) • Panel mount, various terminal types
Contact Ratings			
Contact Form	2A, 2C	1A	1A, 1B, 1C
Contact Material	AgSnO ₂ , AgCdO	AgSnO ₂	AgCe
Max. Switching Current (Resistive load)			
Max. Switching Voltage	277VAC	277VAC	240VAC
Max. Switching Power	8310VA	4432VA	3840VA
Rated Load (Resistive load)	NO: 30A 250VAC/30A 277VAC NC: 3A 250VAC/3A 277VAC	16A 250VAC 16A 30VDC	1A,1B: 16A 120/240VAC 1C: 8A 120/240VAC
Coil Ratings			
Rated Voltage	24VAC to 277VAC 5VDC to 110VDC	3VDC to 36VDC	6VAC to 277VAC / 6VDC to 120VDC
Nominal Operating Power	4.0VA, 1.7W	0.54W	3.5VA, 2.1W
Specifications			
Insulation Resistance	1000MΩ	1200MΩ	500MΩ
Dielectric Strength (Between coil and contacts)	4000VAC	4000VAC	2500VAC
Ambient Temperature	AC : -40°C to 65°C DC: -40°C to 85°C	-40°C to 85°C	-40°C to 65°C
Operate / Release Time max.	25ms / 25ms(DC type)	15ms / 5ms	25ms / 25ms
Mechanical Endurance min.	5 x 10 ⁶ OPS	1 x 10 ⁷ OPS	1 x 10 ⁶ OPS
Electrical Endurance min.	1 x 10 ⁵ OPS	1 x 10 ⁷ OPS	1 x 10 ⁵ OPS (at 16A 250VAC)
Layout (Bottom view)			
Terminal Type	PCB, QC	PCB, QC	QC
Approved Standards	UL/CUL VDE CQC	UL/CUL VDE CQC	UL/CUL
File No.	E134517 40016109 CQC09002037814(DC type)	E133481 R50375929 CQC17002171481	E134517
Cross Reference	P&B, SCHRACK: T92 FEME: CS/CF30	SONGCHUAN:302	WHITE RODGERS 90-290 to 295 90-203, 204, 205
Page	371	375	378

Note: Specification and dimensions in this catalog are subject to change without notice.

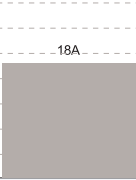
POWER RELAY SELECTION CHART

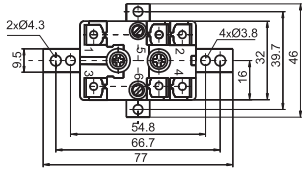
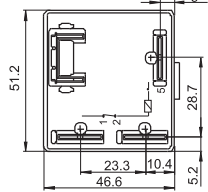
Type	HF94F	HF8565	
Appearance			
Dimensions(L x W x H) mm	47.0 x 32.0 x 28.5	51.2 x 46.6 x 36.5	
Features	<ul style="list-style-type: none"> • 25A switching capability • 2kV dielectric strength (between coil and contacts) • Panel mount, various terminal types 	<ul style="list-style-type: none"> • Motor start potential relay • 50A switching capability • 1 Form B configurations • 250" quick connect termination • Variety of mounting positions 	
Contact Ratings			
Contact Form	1A, 1B, 1C, 1A+1B	1B	
Contact Material	AgCe, AgCdO	AgCdO	
Max. Switching Current (Resistive load)			
Max. Switching Voltage	277VAC		
Max. Switching Power	4986VA		
Rated Load (Resistive load)	18A 277VAC	16A(make and break) 400VAC 35A(break only) 400VAC 50A(break only) 400VAC	
Coil Ratings			
Rated Voltage	6VAC to 277VAC / 6VDC to 120VDC		
Nominal Operating Power	4.0VA, 2.4W	5.0VA	
Specifications			
Insulation Resistance	500MΩ		
Dielectric Strength (Between coil and contacts)	2000VAC		
Ambient Temperature	-40°C to 65°C		
Operate / Release Time max.	25ms / 25ms		
Mechanical Endurance min.	1 x 10 ⁶ OPS	7.5 x 10 ⁵ OPS	
Electrical Endurance min.	5 x 10 ⁴ OPS (at 25A 277VAC)	5 x 10 ⁵ OPS (at 16A 400VAC)	
Layout (Bottom view)			
Terminal Type	QC		
Approved Standards	UL/CUL		
File No.	E134517	SA13318	
Cross Reference	WHITE RODGERS 90-360, 362, 364 90-370, 372, 374 90-380, 382, 384	GE: 3ARR22 ELECTRICA: RVA	
Page	380	383	

Note: Specification and dimensions in this catalog are subject to change without notice.